

Drawing I-25507

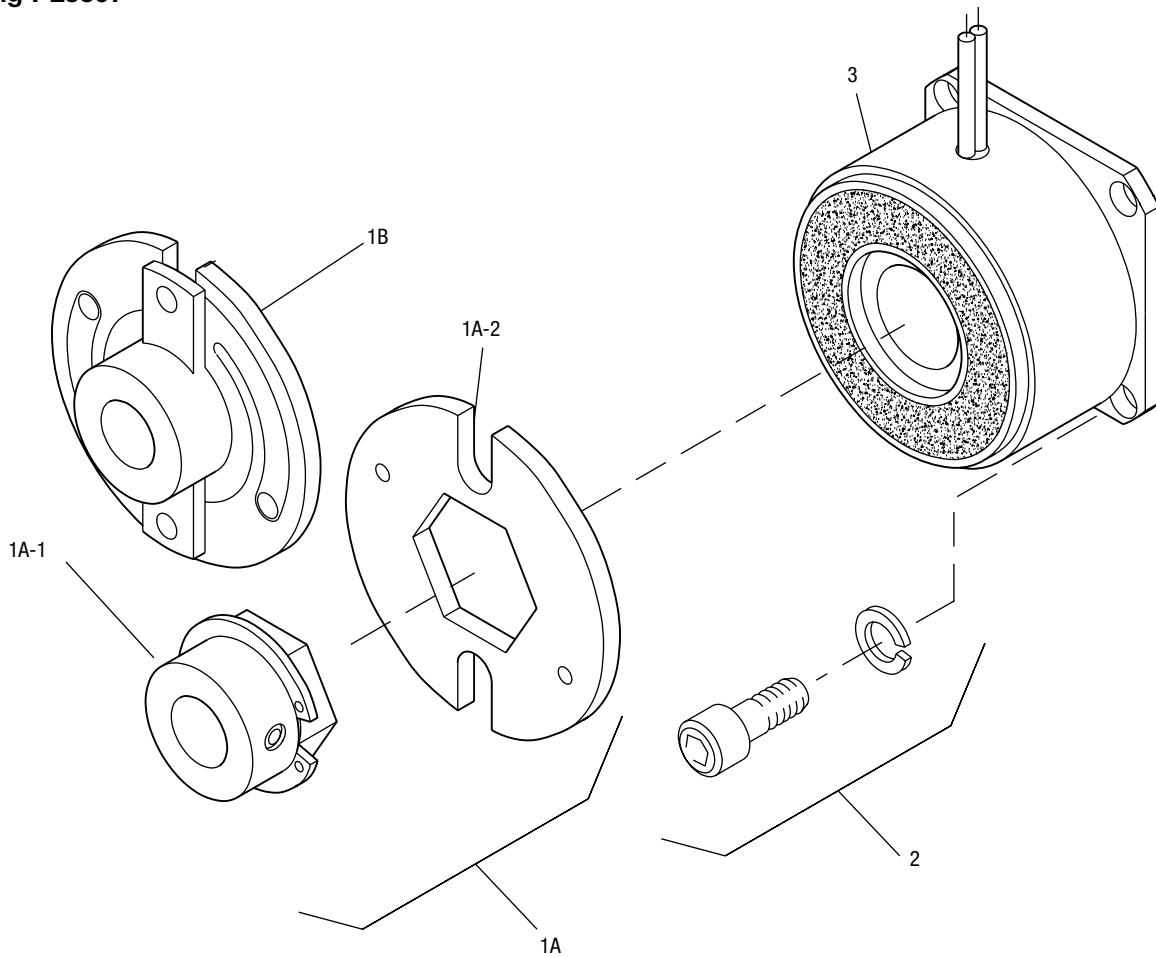

Item	Description	Part Number	Qty.
1A	Armature and Hub		
1A-1	Armature Hub		1
	3/16" Bore	5622-541-009	
	1/4" Bore	5622-541-008	
1A-2	Armature	110-0110	1
1B	Antibacklash Armature		1
	3/16" Bore	5622-111-004	
	1/4" Bore	5622-111-002	
	5/16" Bore	5622-111-003	
2	Mounting Accessory	5101-101-001	1
3	Magnet		1
	6 Volt	5373-631-003	
	24 Volt	5373-631-005	
	90 Volt	5373-631-007	

How to Order:

1. Specify Type of Armature Desired.
2. Specify Bore Size for Item 1A-1 or 1B.
3. Specify Voltage for Item 3.
4. See Controls Section.

Example:

PB-120 Brake per I-25507 - 90 Volt, Standard Armature 3/16" Hub Bore

These units meet the standards of UL508 and are listed under guide card #NMTR, file #59164.

These units are CSA certified under file #LR11543.

Refer to Service Manual P-0201-WE

PB Series Brake

PB-170

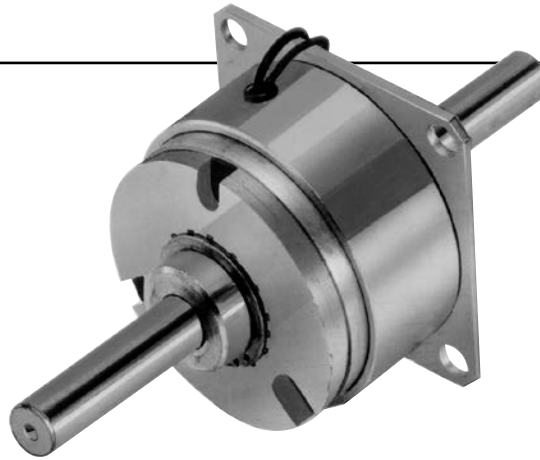

For Bore sizes see chart below.

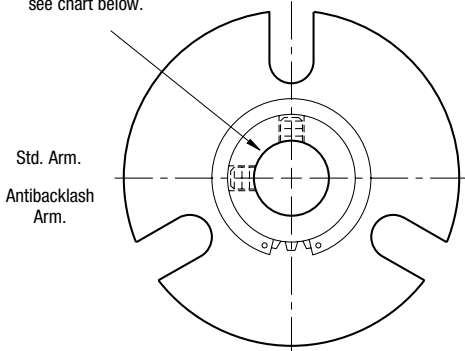

ARMATURE VIEW

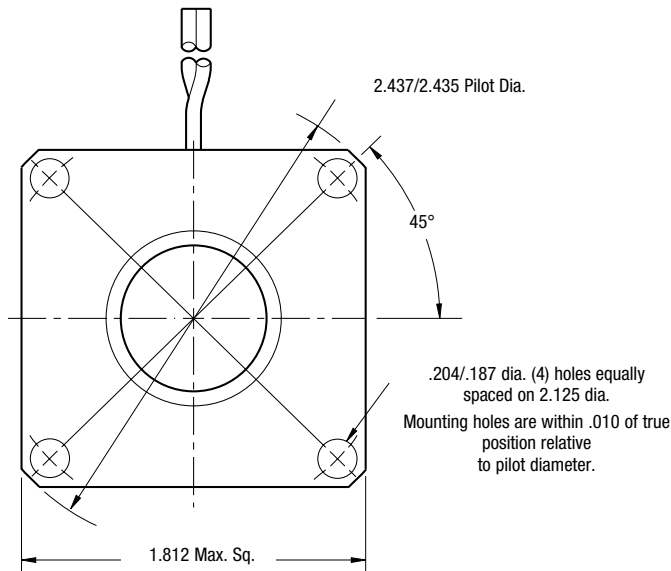

MAGNET VIEW

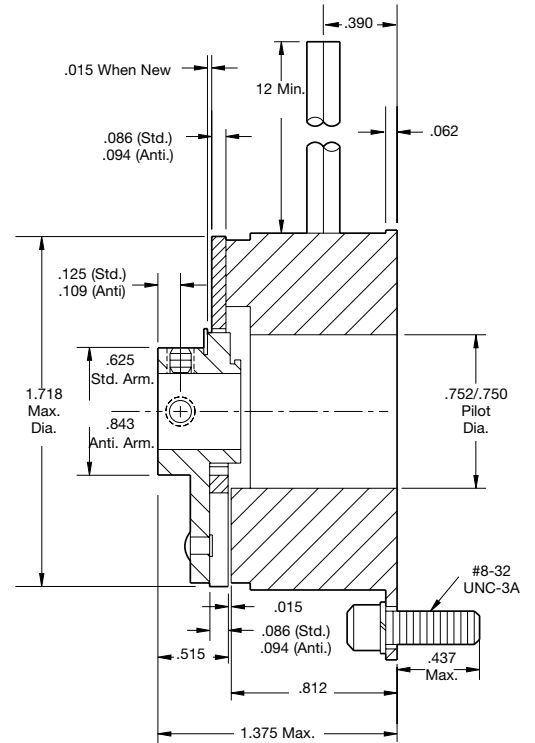

Bore Dimensions

Armature Bore Dia.	
	.251/.250
	.313/.312
	.376/.375
Static Torque	15 lb.in.
Maximum Speed	10,000 rpm
Standard Voltage	D.C. 6, 24, 90

Customer Shall Maintain:

1. Squareness of brake mounting face with armature shaft within .006 T.I.R.
2. Concentricity of brake mounting pilot diameter with armature shaft within .010 T.I.R.

All dimensions are nominal unless otherwise noted.

Information on inertia and weights begins on page 239. Coil data is on pages 250 and 251.



Drawing I-25753

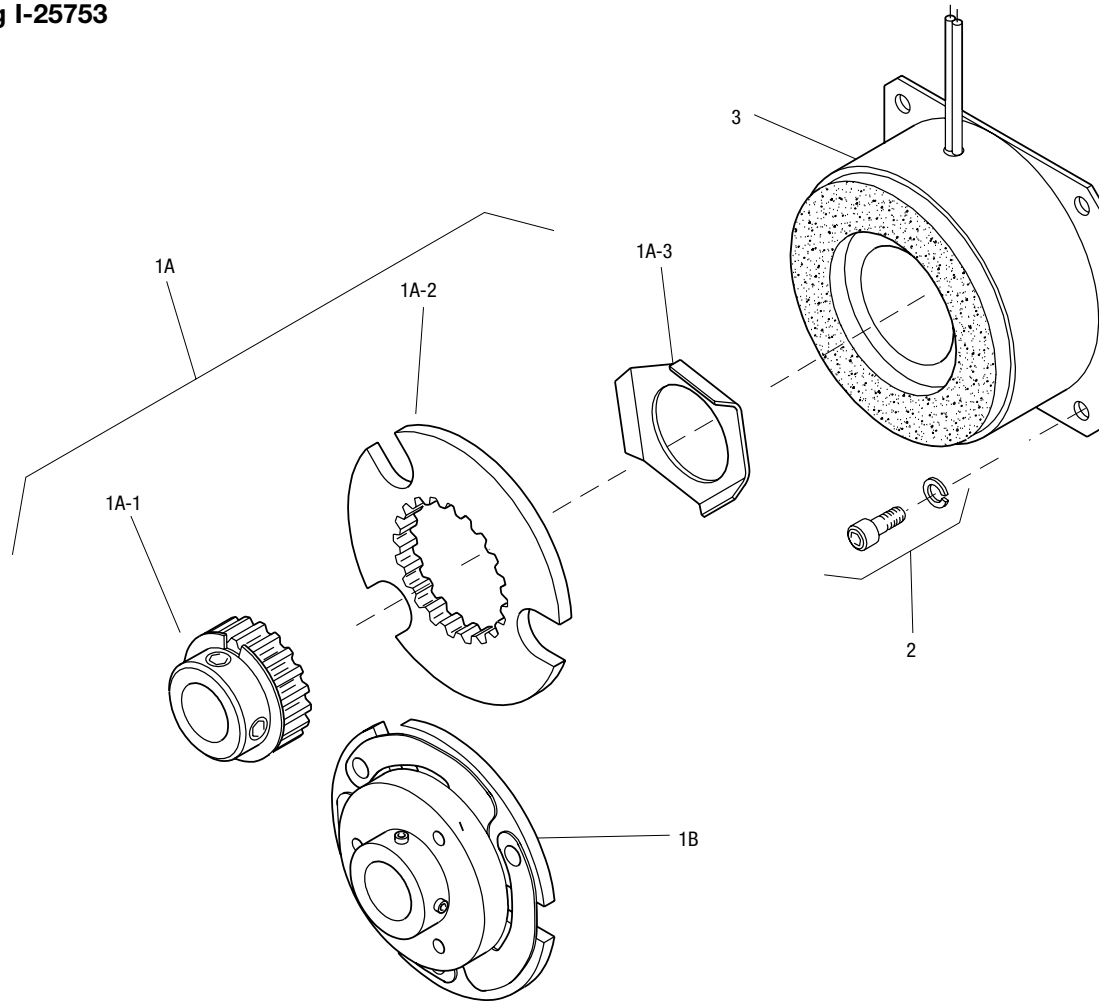

Item	Description	Part Number	Qty.
1A	Armature and Hub		
1A-1	Armature Hub		1
	1/4" Bore	5102-541-002	
	5/16" Bore	5102-541-003	
	3/8" Bore	5102-541-004	
1A-2	Armature	110-0111	1
1A-3	Release Spring	808-0019	1
1B	Antibacklash Armature		1
	1/4" Bore	5623-111-008	
	5/16" Bore	5623-111-009	
	3/8" Bore	5623-111-010	
2	Mounting Accessory	5102-101-001	1
3	Magnet		1
	6 Volt	5375-631-003	
	24 Volt	5375-631-005	
	90 Volt	5375-631-007	

How to Order:

1. Specify Type of Armature Desired.
2. Specify Bore Size for Item 1A-1 or 1B.
3. Specify Voltage for Item 3.
4. See Controls Section.

Example:

PB-170 Brake per I-25753 - 90 Volt,
Antibacklash Armature, 1/4" Armature Hub Bore

These units meet the standards of UL508 and are listed
under guide card #NMTR2, file #59164.

These units are CSA certified under file #LR11543.

Refer to Service Manual P-0201-WE

PB Series Brake

PB-250 Flange Mounted



For Bore & Keyway sizes
see chart below.

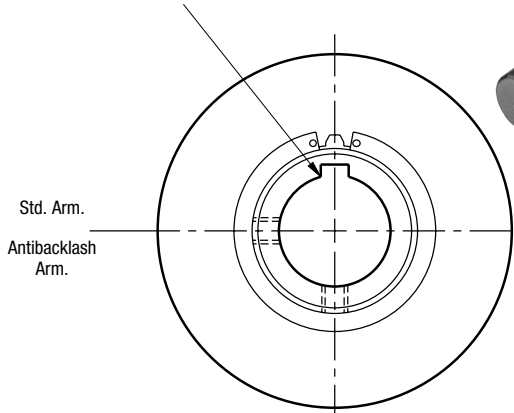

ARMATURE VIEW

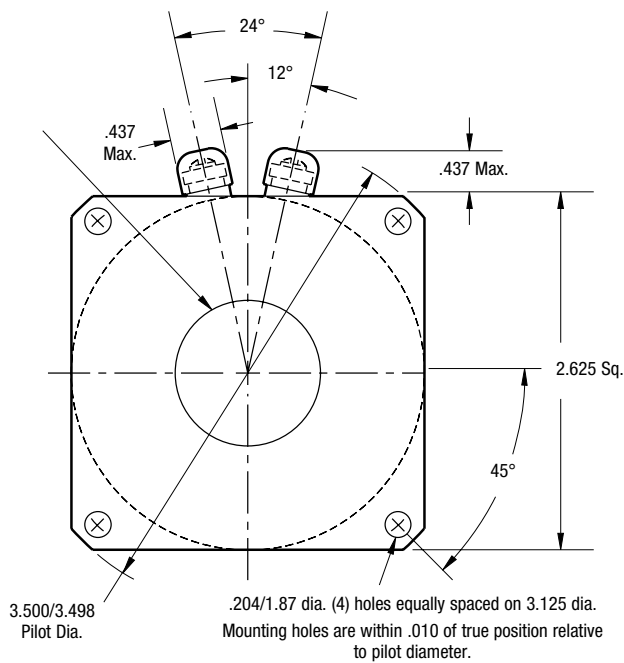

FIELD VIEW

Customer Shall Maintain:

1. Squareness of brake mounting face with armature hub shaft within .006 T.I.R.
2. Concentricity of brake mounting pilot diameter with armature shaft within .010 T.I.R.

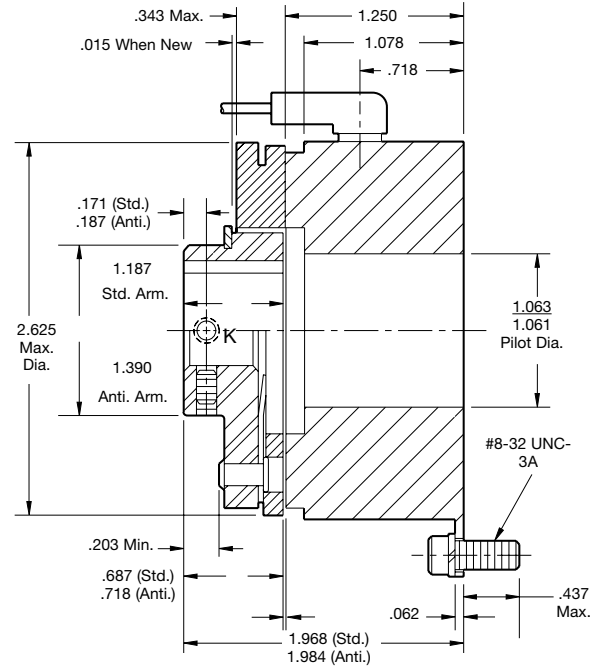

Bore and Keyway Dimensions

Armature Bore Dia.	Keyway
.376/.375	.093 x .046
.438/.437*	.125 x .062
.501/.500	
.563/.562*	
.626/.625	.187 x .093
.688/.687*	
.751/.750	

* Available on special order only.

Static Torque	70 lb.in.
Maximum Speed	7,500 rpm
Standard Voltage	D.C. 6, 24, 90

All dimensions are nominal unless otherwise noted.

Information on inertia and weights begins on page 239. Coil data is on pages 250 and 251.



PB-250 Flange Mounted

Drawing I-25519

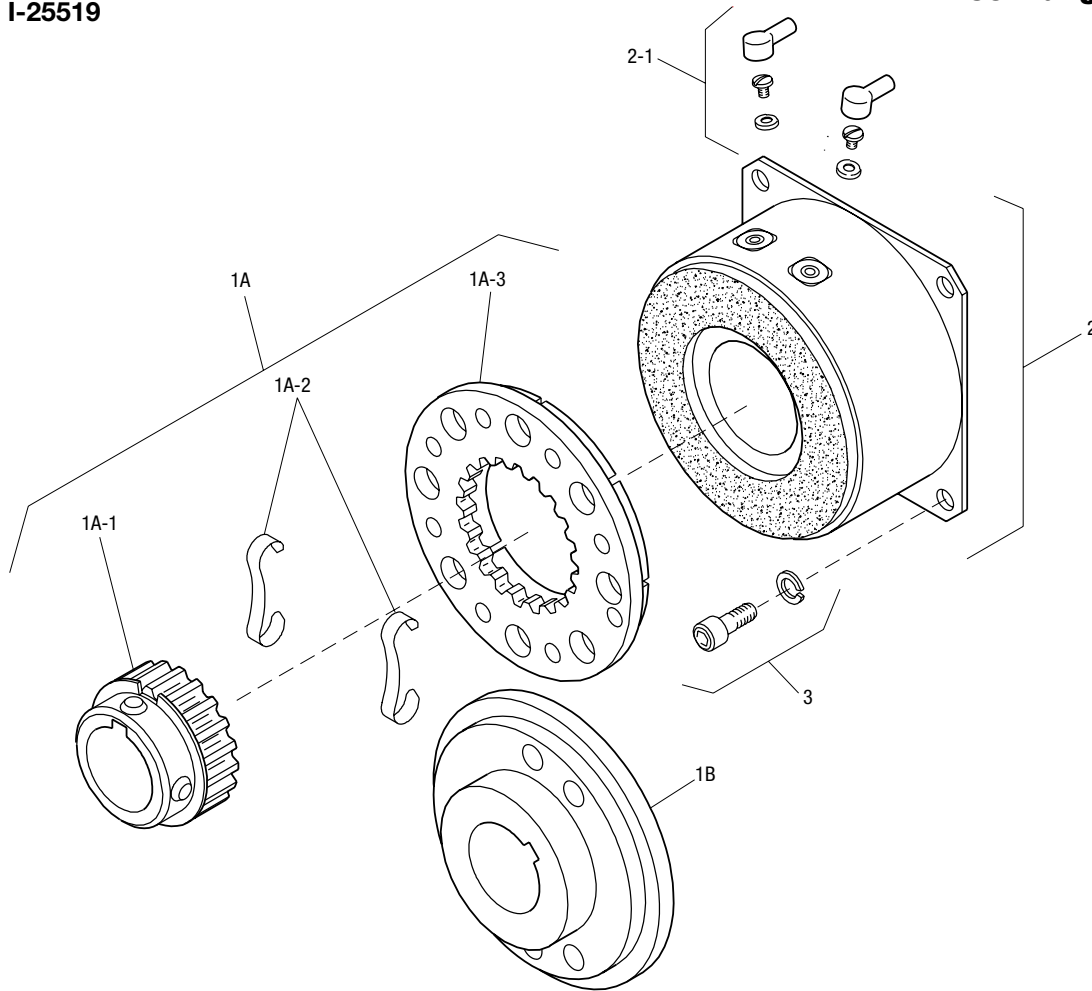

Item	Description	Part Number	Qty.
1A	Armature and Hub		
1A-1	Armature Hub		1
	3/8" Bore	5103-541-002	
	7/16" Bore	5103-541-003	
	1/2" Bore	5103-541-004	
	5/8" Bore	5103-541-006	
	11/16" Bore	5103-541-007	
	3/4" Bore	5103-541-008	
1A-2	Release Spring	5103-101-003	1
1A-3	Armature	5124-111-001	1
1B	Antibrake Armature		1
	3/8" Bore	5365-111-003	
	1/2" Bore	5365-111-005	
	5/8" Bore	5365-111-007	
	3/4" Bore	5365-111-009	
2	Magnet		1
	6 Volt	5319-631-002	
	24 Volt	5319-631-003	
	90 Volt	5319-631-005	

Item	Description	Part Number	Qty.
2-1	Terminal Accessory	5103-101-002	1
3	Mounting Accessory	5102-101-001	1

How to Order:

1. Specify Type of Armature Desired.
2. Specify Bore Size for Item 1A-1 and 1-B.
3. Specify Voltage for Item 2.
4. See Controls Section.

Example:

PB-250 Brake per I-25519 - 90 Volt, Standard Armature, 1/2" Armature Hub Bore

These units meet the standards of UL508 and are listed under guide card #NMTR2, file #59164.

These units are CSA certified under file #LR11543.

Refer to Service Manual P-0201-WE

PB Series Brake

PB-400 Flange Mounted



For Bore & Keyway sizes see chart below.

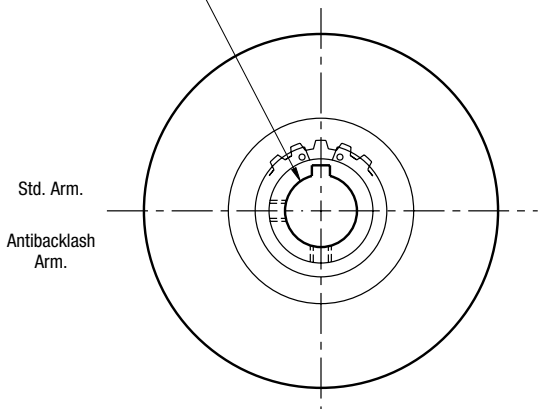

ARMATURE VIEW

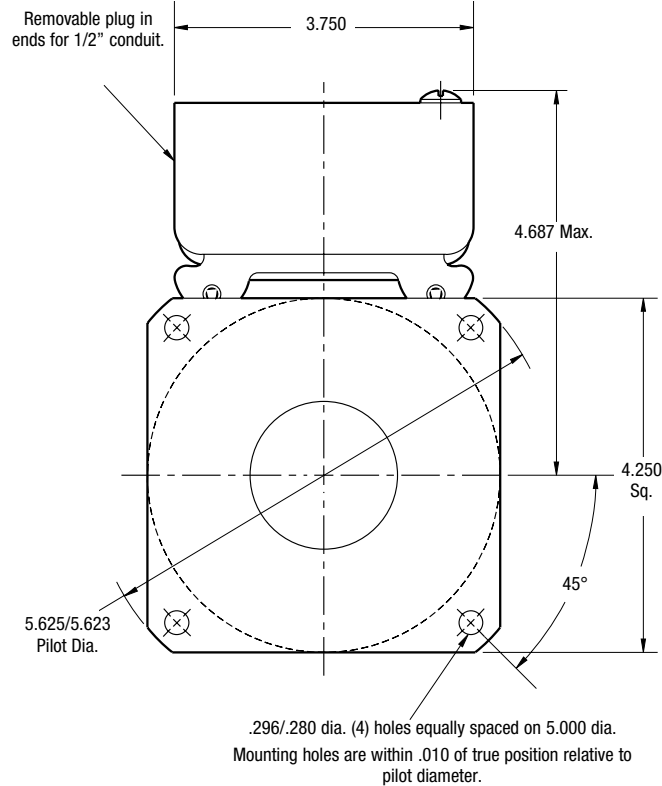

FIELD VIEW

Customer Shall Maintain:

1. Squareness of brake mounting face with armature hub shaft within .006 T.I.R.
2. Concentricity of brake mounting pilot diameter with armature shaft within .010 T.I.R.

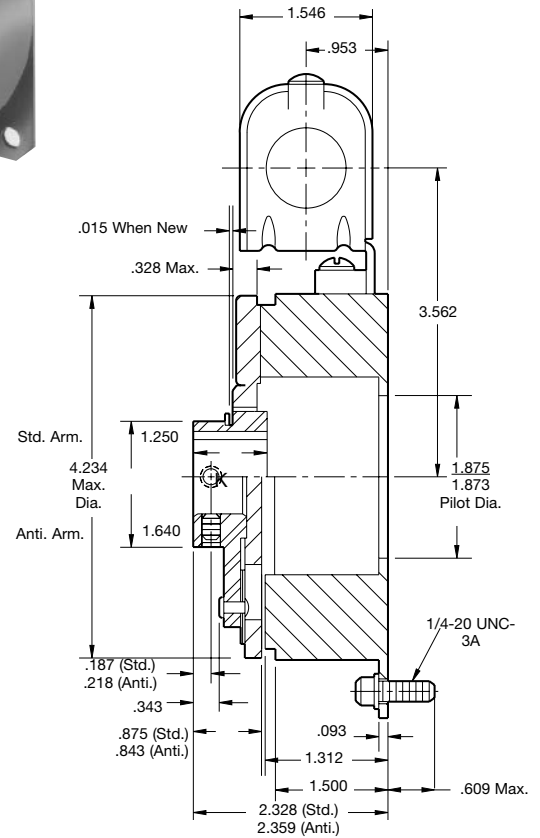

Bore and Keyway Dimensions

Armature Bore Dia.	Keyway
.501/.500	.125 x .062
.563/.562*	
.626/.625	
.688/.687*	
.751/.750	.187 x .093
.876/.875	

* Available on special order only.

Static Torque	270 lb.in.
Maximum Speed	4,500 rpm
Standard Voltage	D.C. 6, 24, 90

All dimensions are nominal unless otherwise noted.

Information on inertia and weights begins on page 239. Coil data is on pages 250 and 251.



PB-400 Flange Mounted

Drawing I-25694

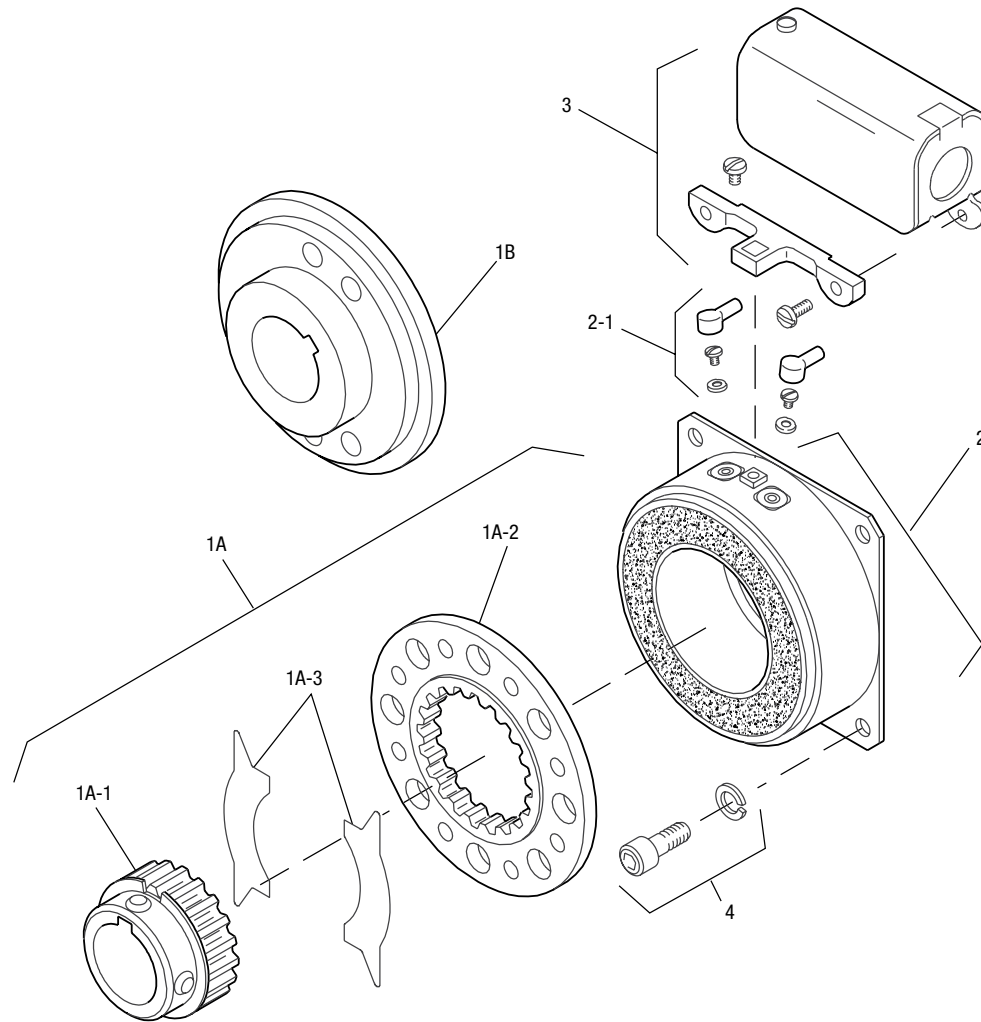

Item	Description	Part Number	Qty.
1A	Armature and Hub		
1A-1	Armature Hub		1
	1/2" Bore	5104-541-002	
	5/8" Bore	5104-541-004	
	3/4" Bore	5104-541-006	
	7/8" Bore	5104-541-007	
1A-2	Armature	5125-111-001	1
1A-3	Release Spring	5104-101-003	1
1B	Antibacklash Armature		1
	1/2" Bore	5367-111-003	
	5/8" Bore	5367-111-005	
	3/4" Bore	5367-111-007	
	7/8" Bore	5367-111-008	
2	Magnet		1
	6 Volt	5115-631-002	
	24 Volt	5115-631-003	
	90 Volt	5115-631-004	

Item	Description	Part Number	Qty.
2-1	Terminal Accessory	5103-101-002	1
3	Conduit Box	5200-101-010	1
4	Mounting Accessory	5104-101-002	1

How to Order:

1. Specify Type of Armature Desired.
2. Specify Bore Size for Item 1A-1 or 1B.
3. Specify Voltage for Item 2.
4. See Controls Section.

Example:

PB-400 Brake per I-25694 - 90 Volt,
Antibacklash Armature
3/4" Armature Hub Bore

These units meet standards set forth in UL508 and are listed under guide card #NMTR, file #59164. These units are CSA certified under file #LR11543.

Refer to Service Manual P-0201-WE

PB Series Brake

PB-500 Normal Duty

See page 252 for details on Bushings.

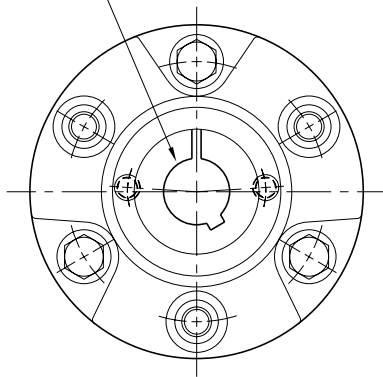

HUB VIEW

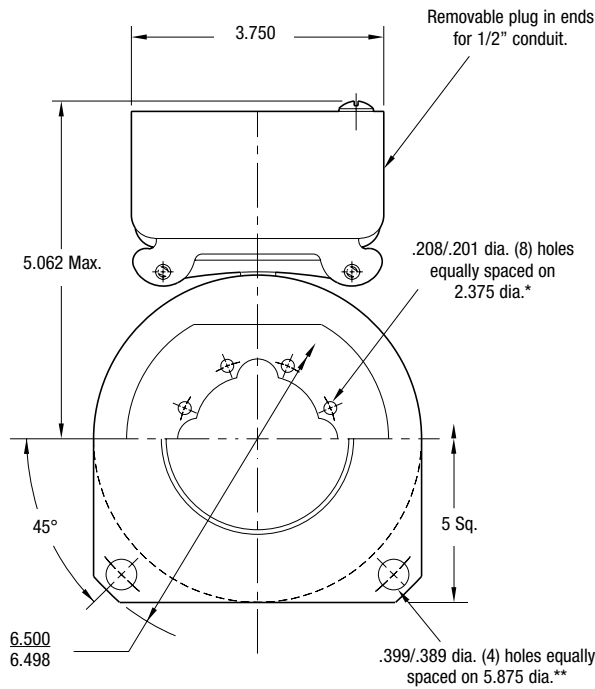

MAGNET VIEW
(Inside & Outside Mounted)

* Mounting holes are within .010 of true position relative to pilot diameter.

** Mounting holes are within .008 of true position relative to pilot diameter.

Customer Shall Maintain:

1. Squareness of brake mounting face with armature hub shaft within .006 T.I.R.
2. Concentricity of brake mounting pilot diameter with armature hub shaft within .010 T.I.R

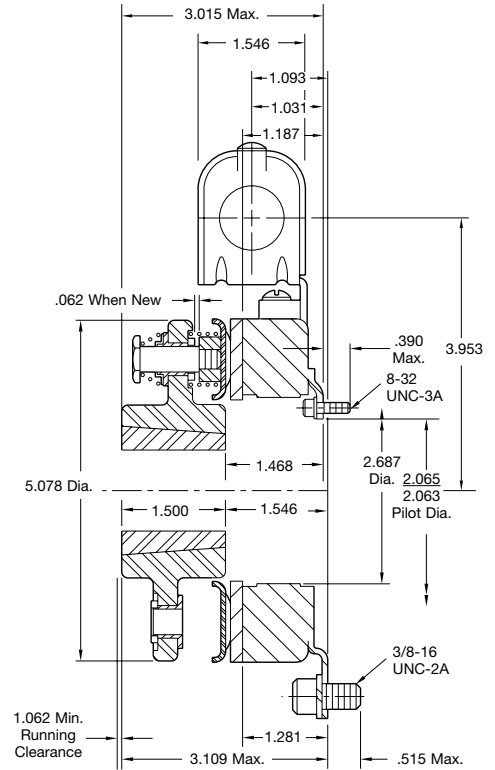

Outside Mounted Offset Backing Plate

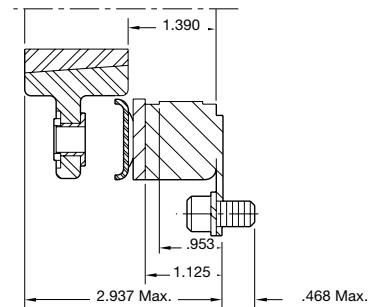

Outside Mounted Flush Backing Plate

Static Torque	40 lb.ft.
Maximum Speed	5,400 rpm
Standard Voltage	D.C. 6, 24, 90

All dimensions are nominal unless otherwise noted.

Information on inertia and weights begins on page 239. Coil data is on pages 250 and 251.



PB-500 Normal Duty

Drawing I-25544

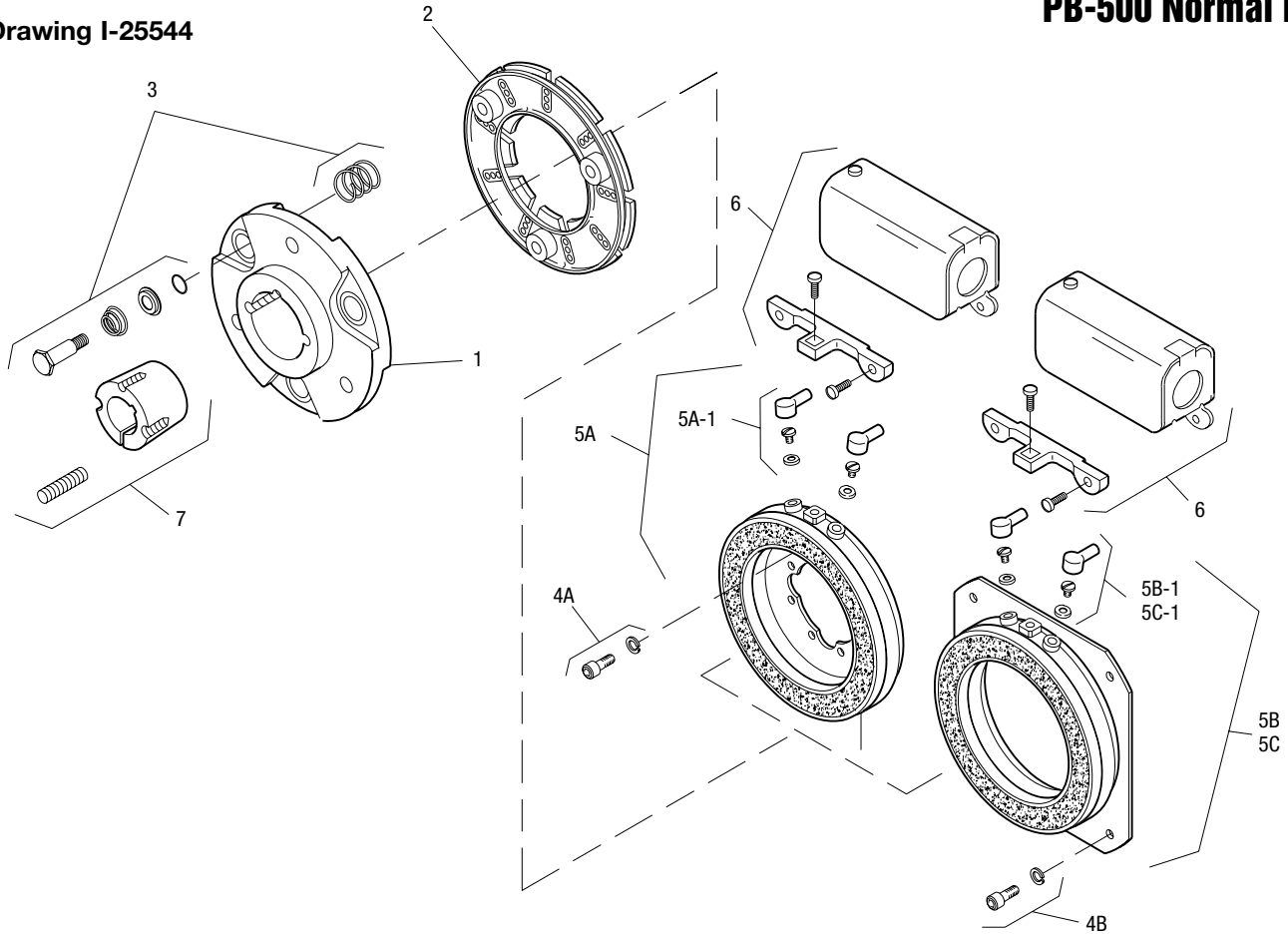

Item	Description	Part Number	Qty.
1	Armature Hub		1
	Standard Hub	5300-541-004	
	Optional Bronze Bushings	5300-541-014	
2	Armature		1
	Segmented-Standard	5300-111-002	
	Solid	110-0241	
3	Autogap Accessory	5200-101-009	3
4A	Mounting Accessory - I.M.	5102-101-001	2
4B	Mounting Accessory - O.M.	5300-101-008	1
5A	Magnet - I.M.		1
	6 Volt	5300-631-002	
	24 Volt	5300-631-003	
	90 Volt	5300-631-005	
	†90 Volt LK Facing	5300-631-020	
5A-1	Terminal Accessory	5311-101-001	1
5B	Magnet - O.M. - Offset		1
	90 Volt	5300-631-014	
	5B-1	Terminal Accessory	5311-101-001
5C	Magnet - O.M. - Flush		1
	6 Volt	5300-631-009	
	24 Volt	5300-631-010	
	90 Volt	5300-631-011	
	†90 Volt LK Facing	5300-631-025	

Item	Description	Part Number	Qty.
5C-1	Terminal Accessory	5311-101-001	1
6	Conduit Box	5200-101-010	1
7	Bushing*		1
		1/2" to 1-1/4" Bore	180-0116 to 180-0128

How to Order:

1. Specify Bore Size for Item 7.
2. Specify Voltage for Item 5A, 5B, or 5C.
3. Specify Inside Mounted for Item 5A and Outside Mounted (Offset) for Item 5B or Outside Mounted (Flush) for Item 5C.
4. See Controls Section.

Example:

PB-500 Brake per I-25544 - 90 Volt, Inside Mounted, 3/4" Bore

These units, when used in conjunction with the correct Warner Electric conduit box, meet the standards of UL508 and are listed under guide card #NMTR, file #59164. These units are CSA certified under file #LR11543.

*See page 252 for specific part numbers.

Refer to Service Manual P-0204-WE

†Optional LK facing available. For more information, see page 232.

PB Series Brake

PB-500 Heavy Duty

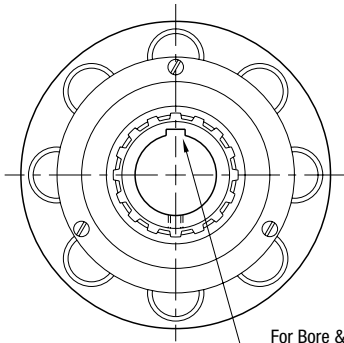

For Bore & Keyway sizes see chart below.

ARMATURE VIEW

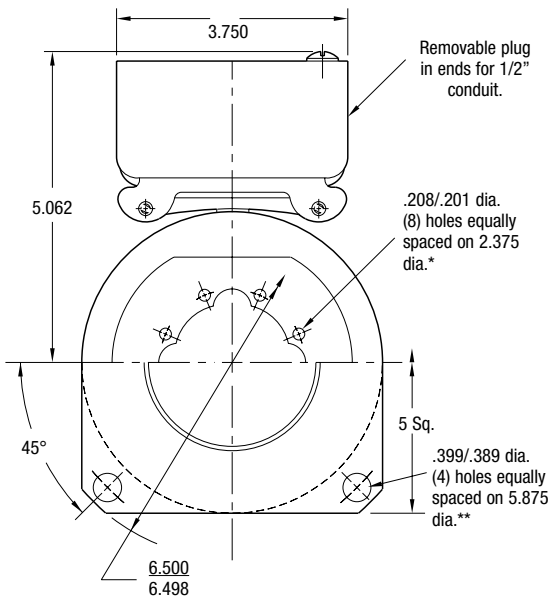

MAGNET VIEW (Inside & Outside Mounted)

* Mounting holes are within .010 of true position relative to pilot diameter.

** Mounting holes are within .008 of true position relative to pilot diameter.

Customer Shall Maintain:

1. Squareness of brake mounting face with armature hub shaft within .006 T.I.R.
2. Concentricity of brake mounting pilot diameter with armature hub shaft within .010 T.I.R.

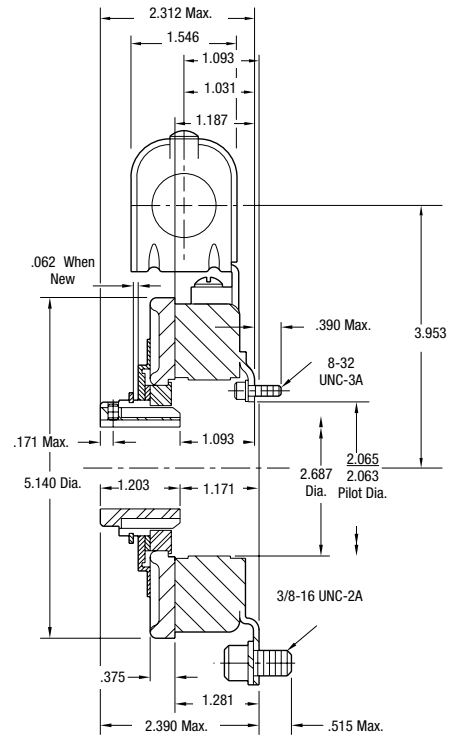

Outside Mounted Offset Backing Plate

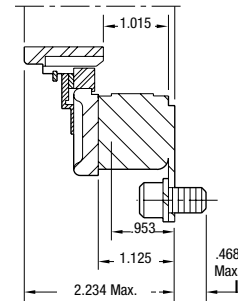

Outside Mounted Flush Backing Plate

Bore and Keyway Dimensions

Armature Bore Dia.	Keyway
.751/.750	.187 x .093
.876/.875	
.9385/.9375	
1.001/1.000	
1.126/1.125	.250 x .125
1.251/1.250	

Static Torque 40 lb.ft.

Maximum Speed 5,400 rpm

Standard Voltage D.C. 6, 24, 90

All dimensions are nominal unless otherwise noted.

Information on inertia and weights begins on page 239. Coil data is on pages 250 and 251.



Drawing I-25550

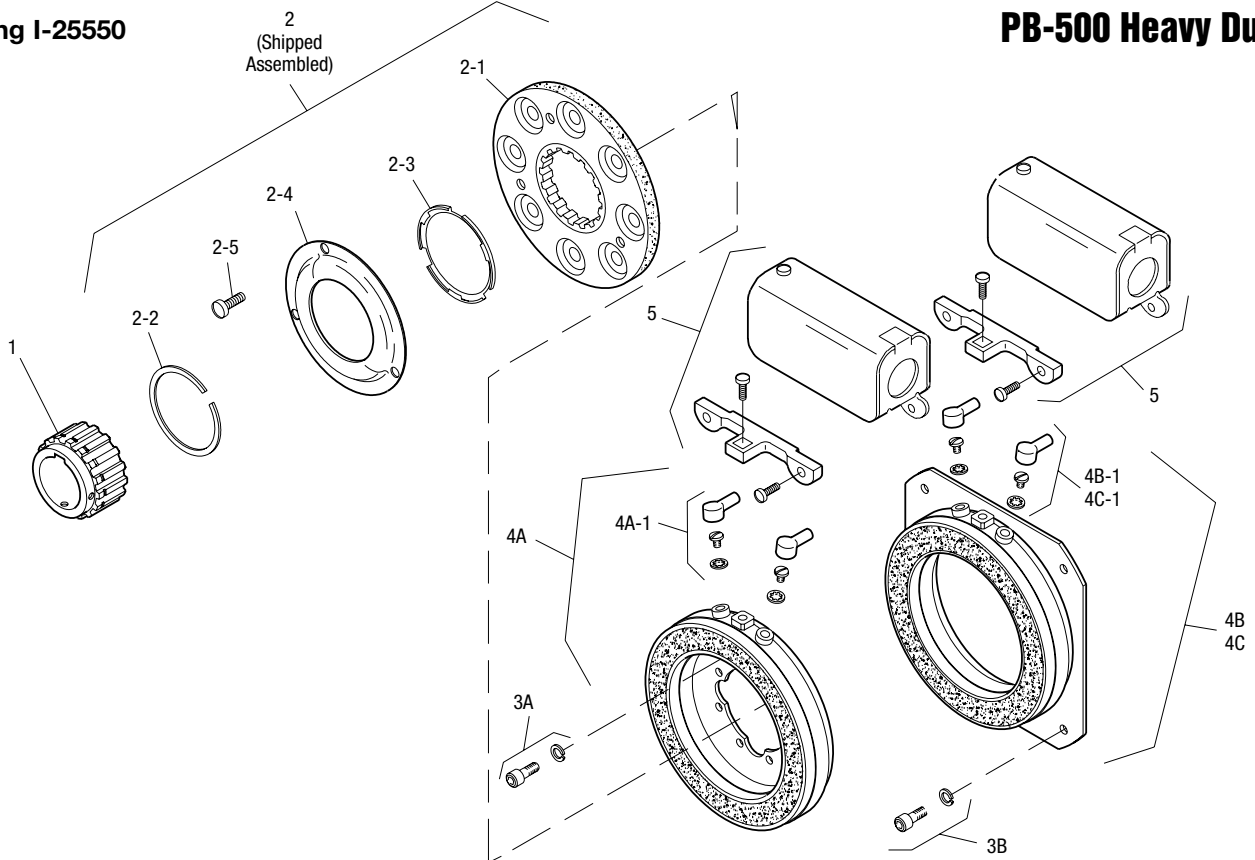

Item	Description	Part Number	Qty.
1	Armature Hub		1
	3/4" Bore	5200-541-002	
	7/8" Bore	5200-541-003	
	15/16" Bore	5200-541-004	
	1" Bore	5200-541-005	
	1-1/8" Bore	5200-541-006	
	1-1/4" Bore	5200-541-007	
	2	Armature Assembly	5230-111-002
2-1	Armature		1
	Segmented	5230-111-001	
	Solid	110-0076	
2-2	Retainer Ring	748-0355	1
2-3	Autogap Spring	808-0412	1
2-4	Retainer Plate	748-0364	1
2-5	Screw	797-0028	3
3A	Mounting Accessory - I.M.	5102-101-001	2
3B	Mounting Accessory - O.M.	5300-101-008	1
4A	Magnet - I.M.		1
	6 Volt	5300-631-002	
	24 Volt	5300-631-003	
	90 Volt	5300-631-005	
	†90 Volt LK Facing	5300-631-020	
4A-1	Terminal Accessory	5311-101-001	1

Item	Description	Part Number	Qty.
4B	Magnet - O.M. - Offset		1
	90 Volt	5300-631-014	
4B-1	Terminal Accessory	5311-101-001	1
4C	Magnet - O.M. - Flush		1
	6 Volt	5300-631-009	
	24 Volt	5300-631-010	
	90 Volt	5300-631-011	
	†90 Volt LK Facing	5300-631-025	
4C-1	Terminal Accessory	5311-101-001	1
5	Conduit Box	5200-101-010	1

How to Order:

1. Specify Bore Size for Item 1.
2. Specify Voltage for Item 4A, 4B, or 4C.
3. Specify Inside Mounted for Item 4A and Outside Mounted (Offset) for Item 4B or Outside Mounted (Flush) for Item 4C.
4. See Controls Section.

Example:

PB-500 Brake per I-25550 - 90 Volt, Inside Mounted, 1" Bore

These units, when used in conjunction with the correct Warner Electric conduit box, meet the standards of UL508 and are listed under guide card #NMTR, file #59164. These units are CSA certified under file #LR11543.

Refer to Service Manual P-0204-WE

†Optional LK facing available. For more information, see page 232.

PB Series Brake

PB-650

See page 252 for details on Bushings.

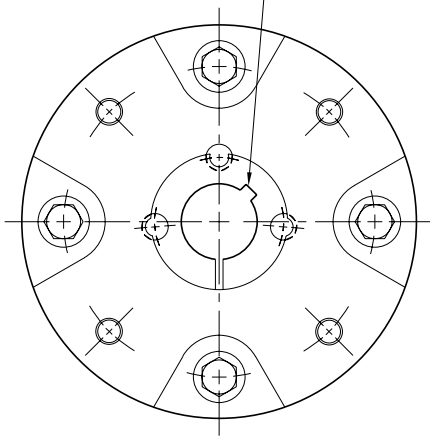

HUB VIEW

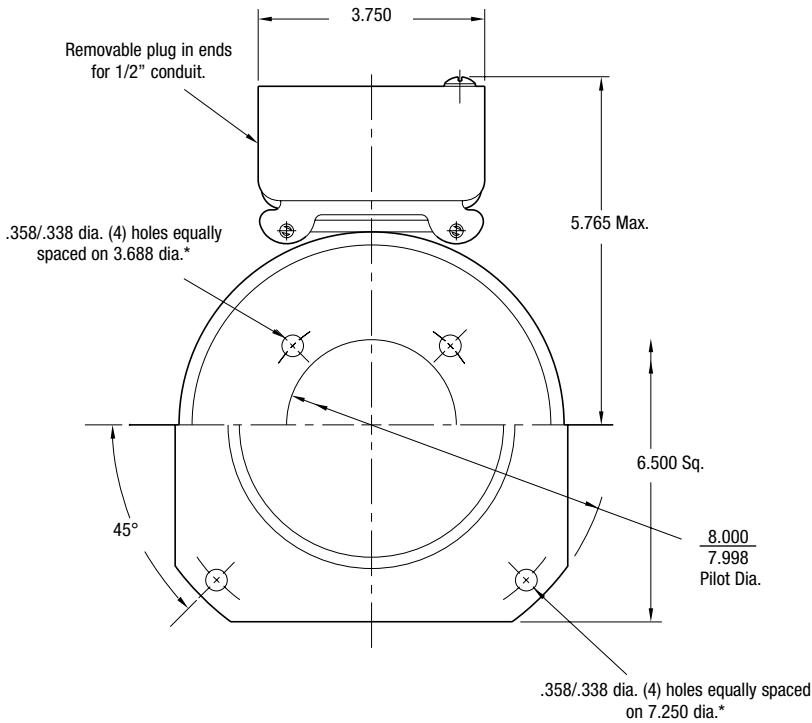

MAGNET VIEW
(Inside & Outside Mounted)

* Mounting holes are within .010 of true position relative to pilot diameter.

Customer Shall Maintain:

1. Squareness of brake mounting face with armature hub shaft within .006 T.I.R.
2. Concentricity of brake mounting pilot diameter with armature hub shaft within .010 T.I.R.

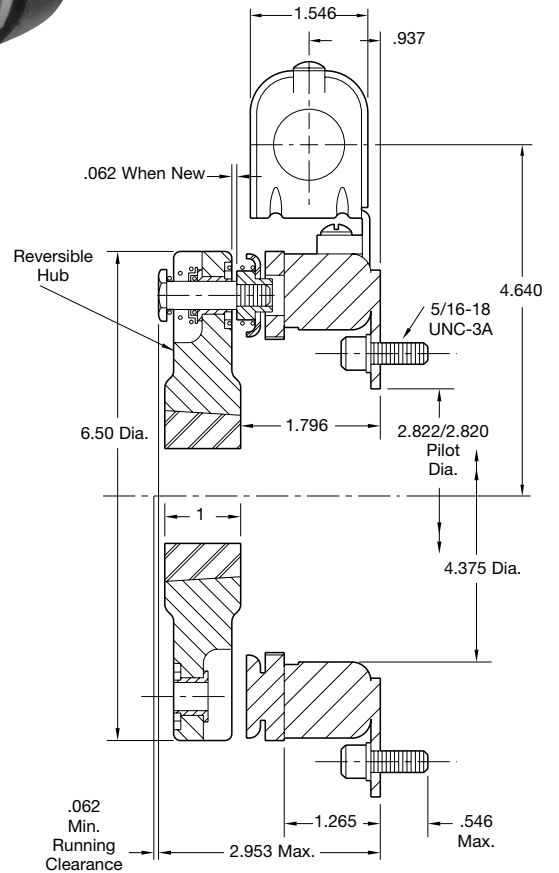

Shaft Sizes	.500 – 1.625
Static Torque	95 lb.ft.
Maximum Speed	3,600 rpm
Standard Voltage	D.C. 6, 24, 90

All dimensions are nominal unless otherwise noted.

Information on inertia and weights begins on page 239. Coil data is on pages 250 and 251.



Drawing I-25730

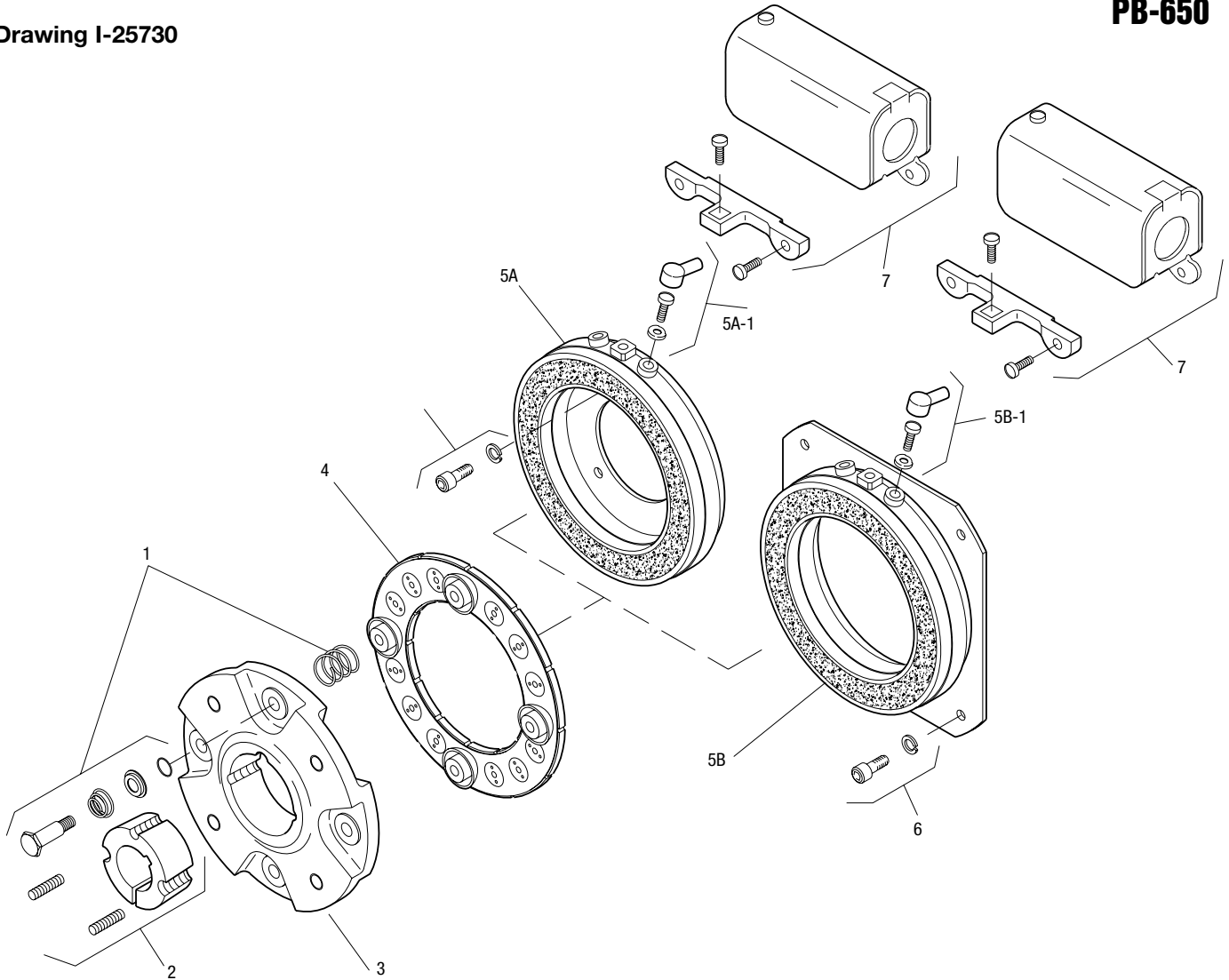

Item	Description	Part Number	Qty.
1	Autogap Accessory	5181-101-010	4
2	Bushing*		1
	1/2" to 1-5/8" Bore	180-0326 to 180-0344	
3	Armature Hub	5207-541-002	1
4	Armature	5281-111-002	1
5A	Magnet - Inside Mounted		1
	6 Volt	5369-631-003	
	24 Volt	5369-631-006	
	90 Volt	5369-631-005	
5A-1	Terminal Accessory	5311-101-001	1
5B	Magnet - Outside Mounted		1
	6 Volt	5369-631-009	
	24 Volt	5369-631-012	
	90 Volt	5369-631-011	
5B-1	Terminal Accessory	5311-101-001	1
6	Mounting Accessory	5321-101-002	1
7	Conduit Box	5200-101-010	1

How to Order:

1. Specify Bore Size for Item 2.
2. Specify Voltage for Item 5.
3. Specify Inside or Outside Mounted for Item 5.
4. See Controls Section.

Example:

PB-650 Brake per I-25730 - 90 Volt, 1" Bore

These units, when used in conjunction with the correct Warner Electric conduit box, meet the standards of UL508 and are listed under guide card #NMTR, file #59164. These units are CSA certified under file #LR11543.

*See page 252 for specific part numbers.

Refer to Service Manual P-0204-WE

PB Series Brake

PB-825 Normal Duty



See page 252 for details on Bushings.

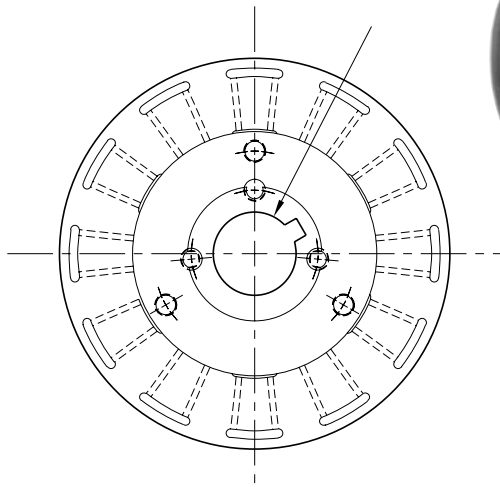

ARMATURE VIEW

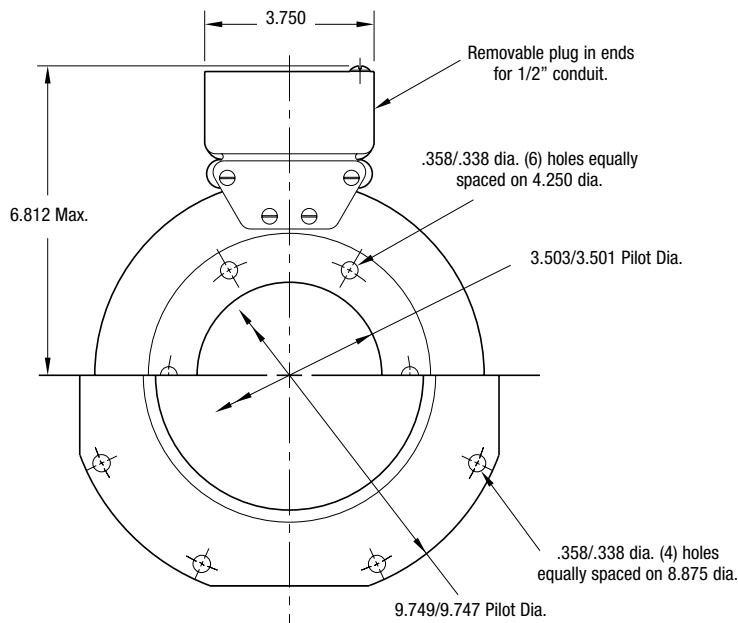

**MAGNET VIEW
(Inside & Outside Mounted)**

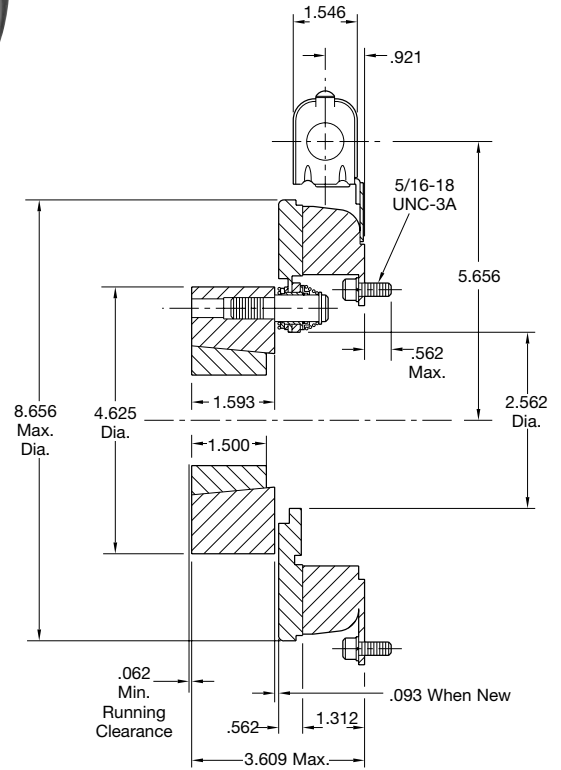

* Mounting holes are within .010 of true positioning relative to pilot diameter.

Shaft Size	.500 – 1.625
Static Torque	125 lb.ft.
Maximum Speed	4,000 rpm
Standard Voltage	D.C. 6, 24, 90

All dimensions are nominal unless otherwise noted.

Information on inertia and weights begins on page 239. Coil data is on pages 250 and 251.

Customer Shall Maintain:

1. Squareness of magnet mounting face with armature shaft within .006 T.I.R.
2. Concentricity of magnet mounting pilot diameter with armature shaft within .010 T.I.R.



Drawing I-25566

PB-825 Normal Duty

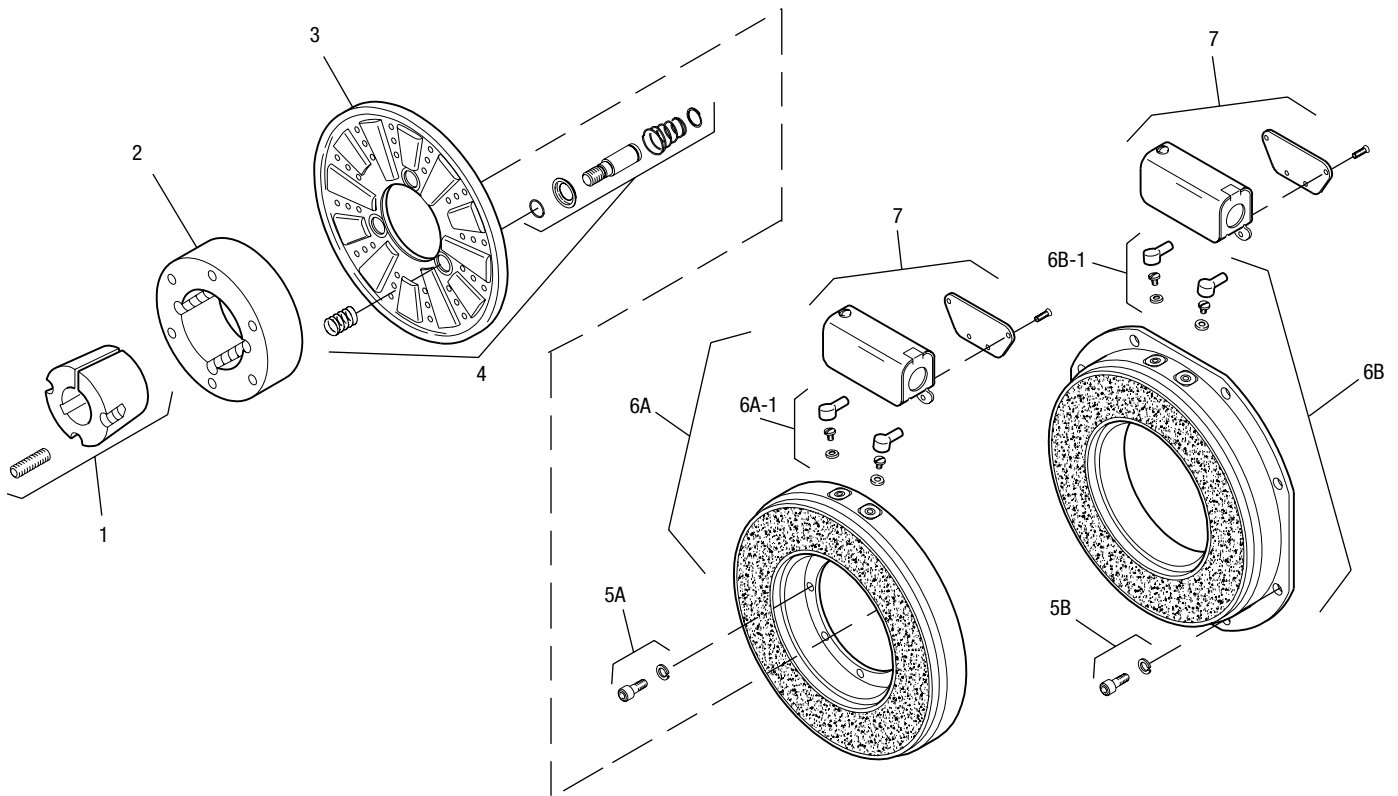

Item	Description	Part Number	Qty.
1	Bushing*		1
	1/2" to 1-5/8" Bore	180-0131 to 180-0149	
2	Armature Hub	540-0394	1
3	Armature	5301-111-018	1
4	Autogap Accessory	5201-101-008	3
5A	Mounting Accessory - I.M.	5321-101-001	1
5B	Mounting Accessory - O.M.	5321-101-002	1
6A	Magnet - Inside Mounted		1
	6 Volt	5311-631-002	
	24 Volt	5311-631-003	
	90 Volt	5311-631-004	
	†90 Volt LK Facing	5311-631-011	
6A-1	Terminal Accessory	5311-101-001	1
6B	Magnet, Outside Mounted		1
	6 Volt	5311-631-007	
	24 Volt	5311-631-009	
	90 Volt	5311-631-008	
	†90 Volt LK Facing	5311-631-012	

Item	Description	Part Number	Qty.
6B-1	Terminal Accessory	5311-101-001	1
7	Conduit Box	5200-101-011	1

How to Order:

1. Specify Bore Size for Item 1.
2. Specify Inside Mounted for Items 5A and 6A or Outside Mounted for Items 5B and 6B.
3. Specify Voltage for Item 6A or 6B.
4. See Controls Section.

Example:

PB-825 Brake per I-25566 - 90 Volt, Inside Mounted, 1" Bore

These units, when used in conjunction with the correct Warner Electric conduit box, meet the standards of UL508 and are listed under guide card #NMTR, file #59164. These units are CSA certified under file #LR11543.

*See page 252 for specific part numbers.

Refer to Service Manual P-0208-WE

†Optional LK facing available. For more information, see page 232.

PB Series Brake

PB-825 Heavy Duty

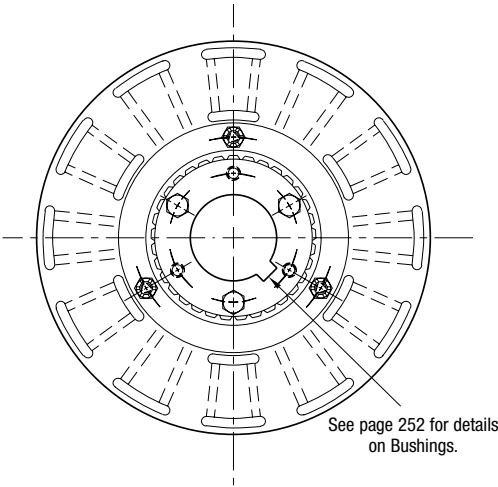

ARMATURE VIEW

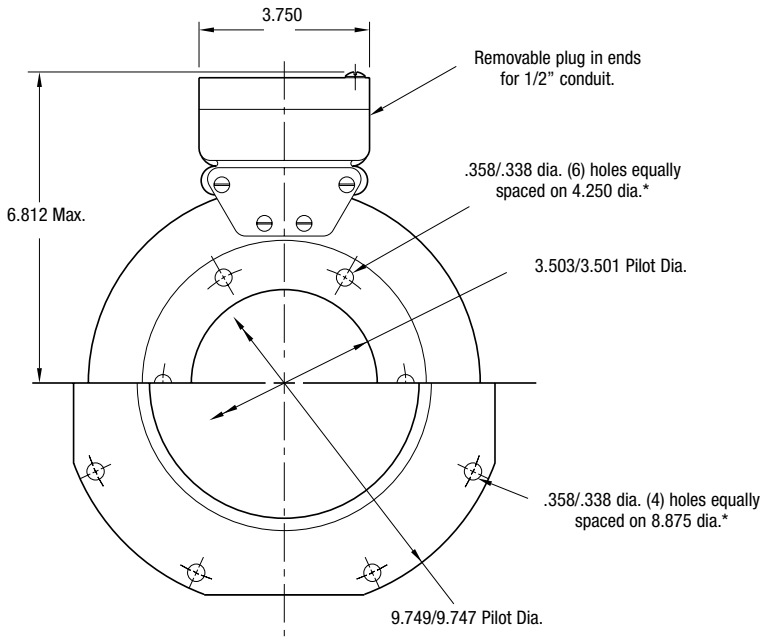

**MAGNET VIEW
(Inside & Outside Mounted)**

* Mounting holes are within .010 of true position relative to pilot diameter.

Customer Shall Maintain:

1. Squareness of magnet mounting face with armature shaft within .006 T.I.R.
2. Concentricity of magnet mounting pilot diameter with armature shaft within .010 T.I.R.

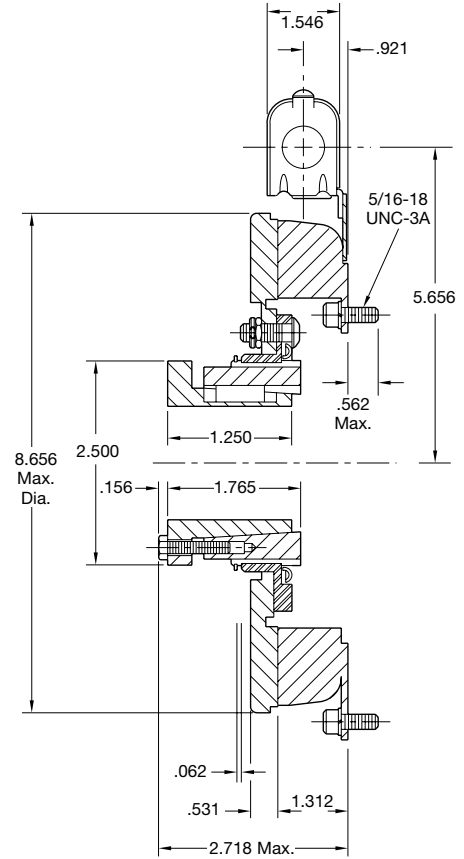

Shaft Size	.500 – 1.500
Static Torque	125 lb.ft.
Maximum Speed	4,000 rpm
Standard Voltage	D.C. 6, 24, 90

All dimensions are nominal unless otherwise noted.

Information on inertia and weights begins on page 239. Coil data is on pages 250 and 251.



Drawing I-25567

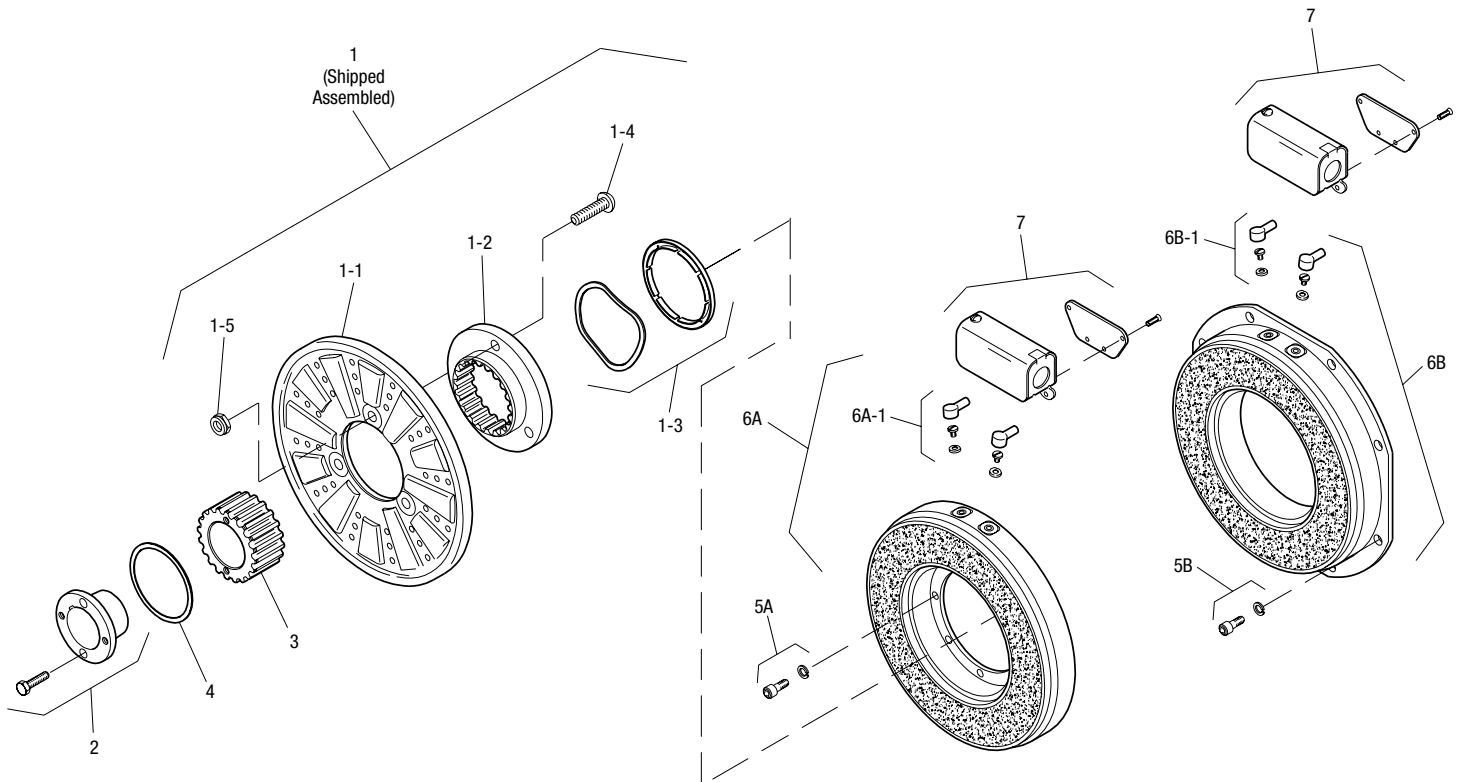

Item	Description	Part Number	Qty.
1	Armature Assembly	5321-111-001	1
1-1	Armature	5321-111-022	1
1-2	Splined Adapter	104-0008	1
1-3	Autogap Accessory	5321-101-006	1
1-4	Screw	797-0272	3
1-5	Locknut	661-0004	3
2	Bushing*		1
	1/2" to 1-1/2" Bore	180-0002 to 180-0018	
3	Splined Hub	540-0057	1
4	Retainer Ring	748-0006	1
5A	Mounting Accessory - I.M.	5321-101-001	1
5B	Mounting Accessory - O.M.	5321-101-002	1
6A	Magnet - Inside Mounted		1
	6 Volt	5311-631-002	
	24 Volt	5311-631-003	
	90 Volt	5311-631-004	
	†90 Volt LK Facing	5311-631-011	
6A-1	Terminal Accessory	5311-101-001	1
6B	Magnet - Outside Mounted		1
	6 Volt	5311-631-007	
	24 Volt	5311-631-009	
	90 Volt	5311-631-008	
	†90 Volt LK Facing	5311-631-012	

Item	Description	Part Number	Qty.
6B-1	Terminal Accessory	5311-101-001	1
7	Conduit Box	5200-101-011	1

How to Order:

1. Specify Bore Size for Item 2.
2. Specify Inside Mounted for Items 5A and 6A or Outside Mounted for Items 5B and 6B.
3. Specify Voltage for Item 6A or 6B.
4. See Controls Section.

Example:

PB-825 Brake per I-25567 - 90 Volt, 1" Bore, Inside Mounted

These units, when used in conjunction with the correct Warner Electric conduit box, meet the standards of UL508 and are listed under guide card #NMTR, file #59164. These units are CSA certified under file #LR11543.

*See page 252 for specific part numbers.

Refer to Service Manual P-0209-WE

†Optional LK facing available. For more information, see page 232.

PB Series Brake

PB-1000 Normal Duty



See page 252 for details on Bushings.

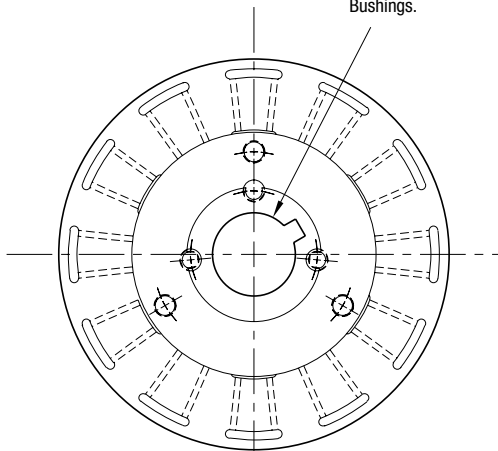

ARMATURE VIEW

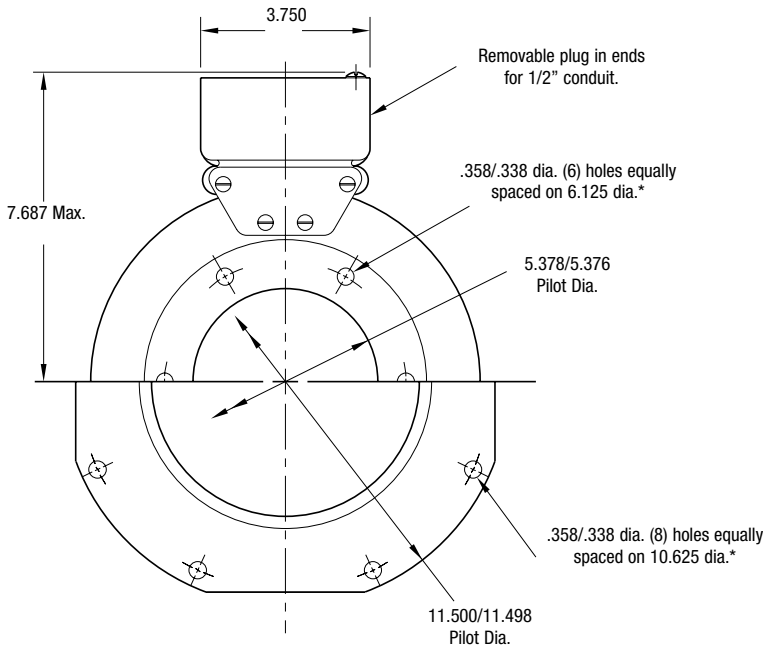

**MAGNET VIEW
(Inside & Outside Mounted)**

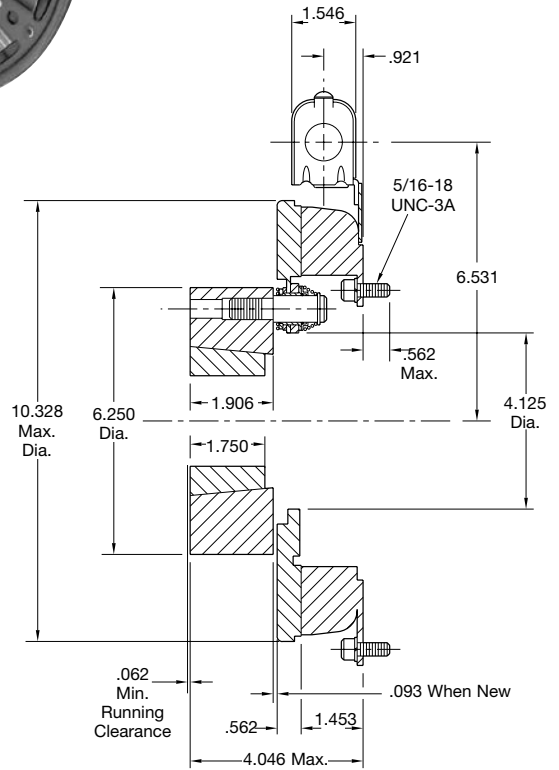

* Mounting holes are within .010 of true position relative to pilot diameter.

Shaft Size	.500 – 2.500
Static Torque	240 lb.ft.
Maximum Speed	3,600 rpm
Standard Voltage	D.C. 6, 24, 90

Customer Shall Maintain:

1. Squareness of magnet mounting face with armature shaft within .006 T.I.R.
2. Concentricity of magnet mounting pilot diameter with armature shaft within .010 T.I.R.

All dimensions are nominal unless otherwise noted.

Information on inertia and weights begins on page 239. Coil data is on pages 250 and 251.



PB-1000 Normal Duty

Drawing I-25586

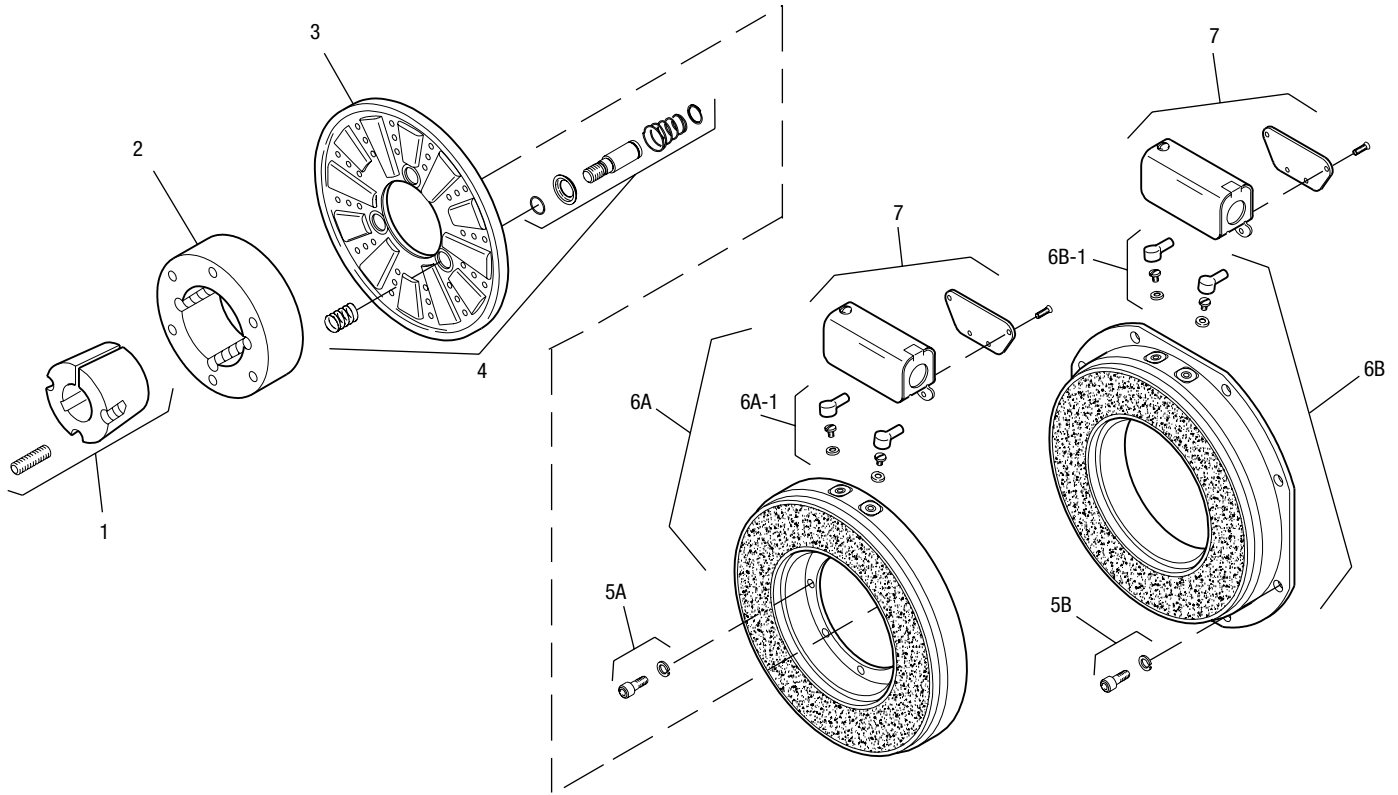

Item	Description	Part Number	Qty.
1	Bushing*		1
	1/2" to 2-1/2" Bore	180-0185 to 180-0217	
2	Armature Hub	540-0313	1
3	Armature	5302-111-013	1
4	Autogap Accessory	5201-101-008	3
5A	Mounting Accessory - I.M.	5321-101-001	1
5B	Mounting Accessory - O.M.	5321-101-002	2
6A	Magnet - Inside Mounted		1
	6 Volt	5312-631-004	
	24 Volt	5312-631-005	
	90 Volt	5312-631-006	
	†90 Volt LK Facing	5312-631-001	
6A-1	Terminal Accessory	5311-101-001	1
6B	Magnet, Outside Mounted		1
	6 Volt	5312-631-011	
	24 Volt	5312-631-013	
	90 Volt	5312-631-012	
	†90 Volt LK Facing	5312-631-002	

Item	Description	Part Number	Qty.
6B-1	Terminal Accessory	5311-101-001	1
7	Conduit Box	5200-101-011	1

How to Order:

1. Specify Bore Size for Item 1.
2. Specify Inside Mounted for Items 5A and 6A or Outside Mounted for Items 5B and 6B.
3. Specify Voltage for Item 6A or 6B.
4. See Controls Section.

Example:

PB-1000 Brake per I-25586 - 90 Volt, Inside Mounted, 1" Bore

These units, when used in conjunction with the correct Warner Electric conduit box, meet the standards of UL508 and are listed under guide card #NMTR, file #59164. These units are CSA certified under file #LR11543.

*See page 252 for specific part numbers.

Refer to Service Manual P-0208-WE

†Optional LK facing available. For more information, see page 232.

PB Series Brake

PB-1000 Heavy Duty

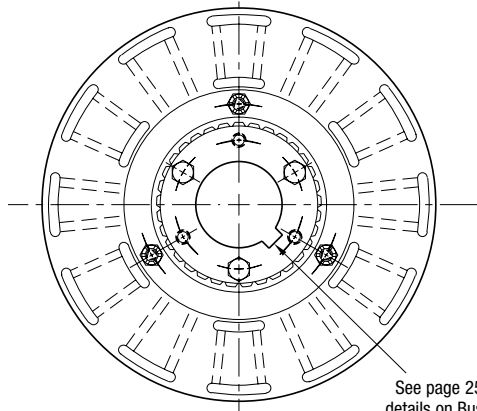

ARMATURE VIEW

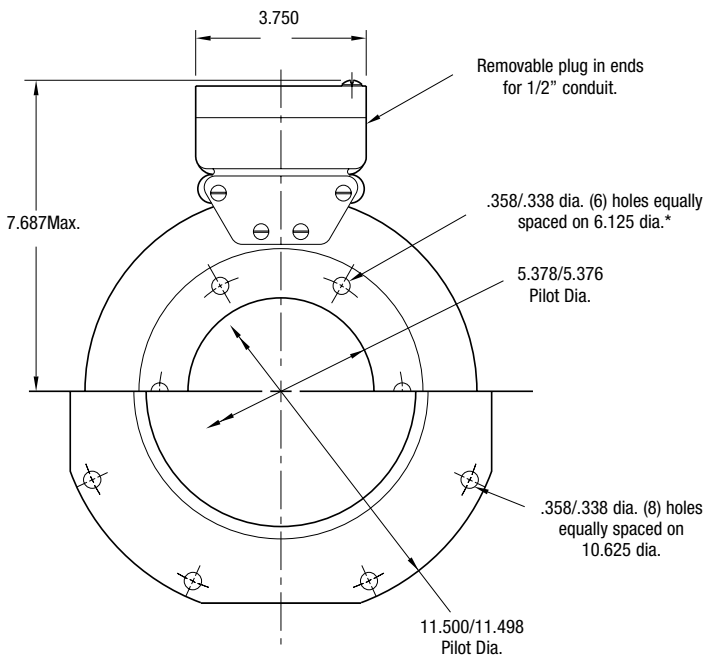

**MAGNET VIEW
(Inside & Outside Mounted)**

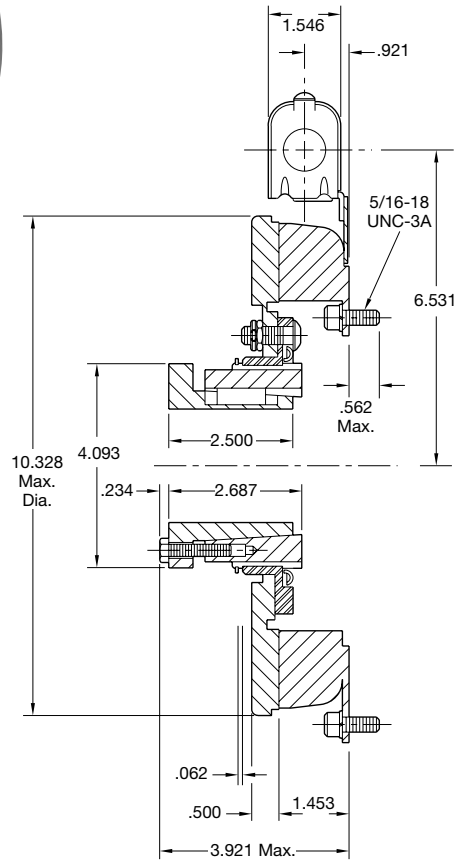

Shaft Size	.750 – 2.687
Static Torque	240 lb.ft.
Maximum Speed	3,600 rpm
Standard Voltage	D.C. 6, 24, 90

* Mounting holes are within .010 of true position relative to pilot diameter.

Customer Shall Maintain:

1. Squareness of magnet mounting face with armature shaft within .006 T.I.R.
2. Concentricity of magnet mounting pilot diameter with armature shaft within .010 T.I.R.



Drawing I-25587

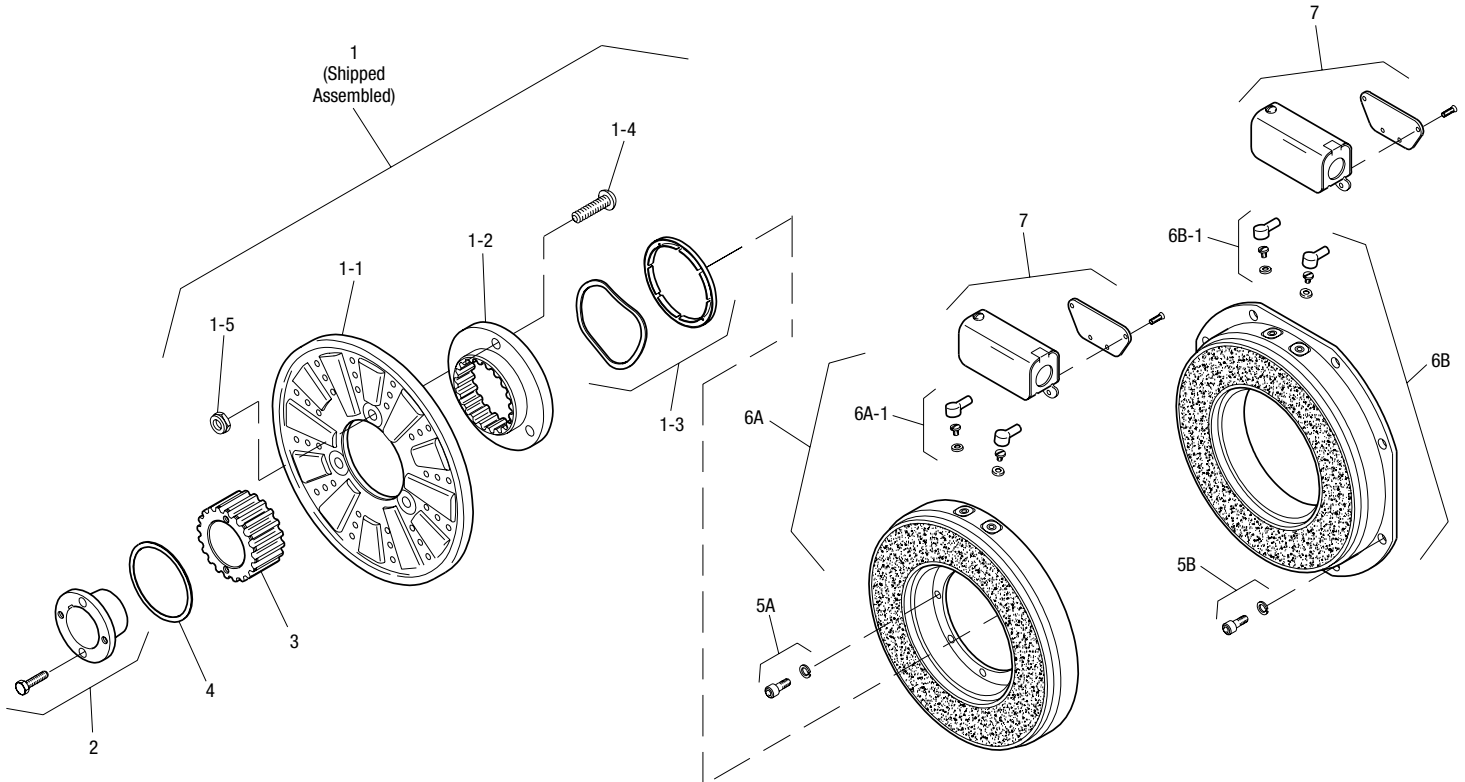

Item	Description	Part Number	Qty.
1	Armature Assembly	5322-111-002	1
1-1	Armature	5322-111-036	1
1-2	Splined Adapter	104-0009	1
1-3	Autogap Accessory	5322-101-004	1
1-4	Screw	797-0272	3
1-5	Locknut	661-0004	3
2	Bushing*		1
	3/4" to 2-11/16" Bore	180-0026 to 180-0057	
3	Splined Hub	540-0062	1
4	Retainer Ring	748-0007	1
5A	Mounting Accessory - I.M.	5321-101-001	1
5B	Mounting Accessory - O.M.	5321-101-002	2
6A	Magnet - Inside Mounted		1
	6 Volt	5312-631-004	
	24 Volt	5312-631-005	
	90 Volt	5312-631-006	
	†90 Volt LK Facing	5312-631-001	
6A-1	Terminal Accessory	5311-101-001	1
6B	Magnet - Outside Mounted		1
	6 Volt	5312-631-011	
	24 Volt	5312-631-013	
	90 Volt	5312-631-012	
	†90 Volt LK Facing	5312-631-002	

Item	Description	Part Number	Qty.
6B-1	Terminal Accessory	5311-101-001	1
7	Conduit Box	5200-101-011	1

How to Order:

1. Specify Bore Size for Item 2.
2. Specify Inside Mounted for Items 5A and 6A or Outside Mounted for Items 5B and 6B.
3. Specify Voltage for Item 6A or 6B.
4. See Controls Section.

Example:

PB-1000 Brake per I-25587 - 90 Volt, 1-1/2" Bore, Inside Mounted

These units, when used in conjunction with the correct Warner Electric conduit box, meet the standards of UL508 and are listed under guide card #NMTR, file #59164. These units are CSA certified under file #LR11543.

*See page 252 for specific part numbers.

Refer to Service Manual P-0209-WE

†Optional LK facing available. For more information, see page 232.

PB Series Brake

PB-1225 Normal Duty



See page 252 for details on Bushings.

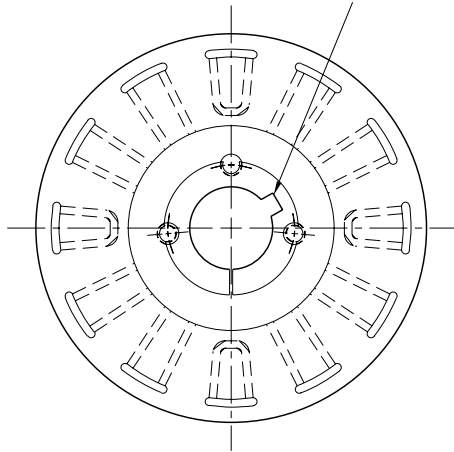

ARMATURE VIEW

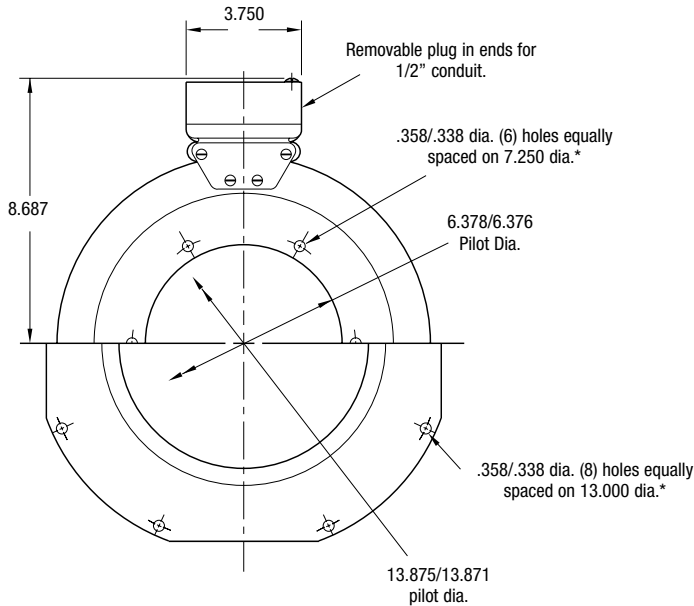

**MAGNET VIEW
(Inside & Outside Mounted)**

* Mounting holes are within .010 of true position relative to pilot diameter.

Customer Shall Maintain:

1. Squareness of magnet mounting face with armature shaft within .006 T.I.R.
2. Concentricity of magnet mounting pilot diameter with armature shaft within .010 T.I.R.

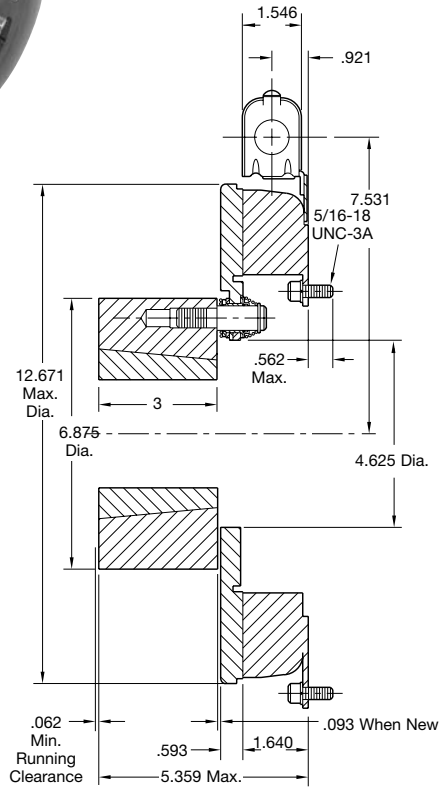

Shaft Size	.937 – 3.000
Static Torque	465 lb. ft.
Maximum Speed	3,000 rpm
Standard Voltage	D.C. 6, 24, 90

All dimensions are nominal unless otherwise noted.

Information on inertia and weights begins on page 239. Coil data is on pages 250 and 251.



PB-1225 Normal Duty

Drawing I-25606

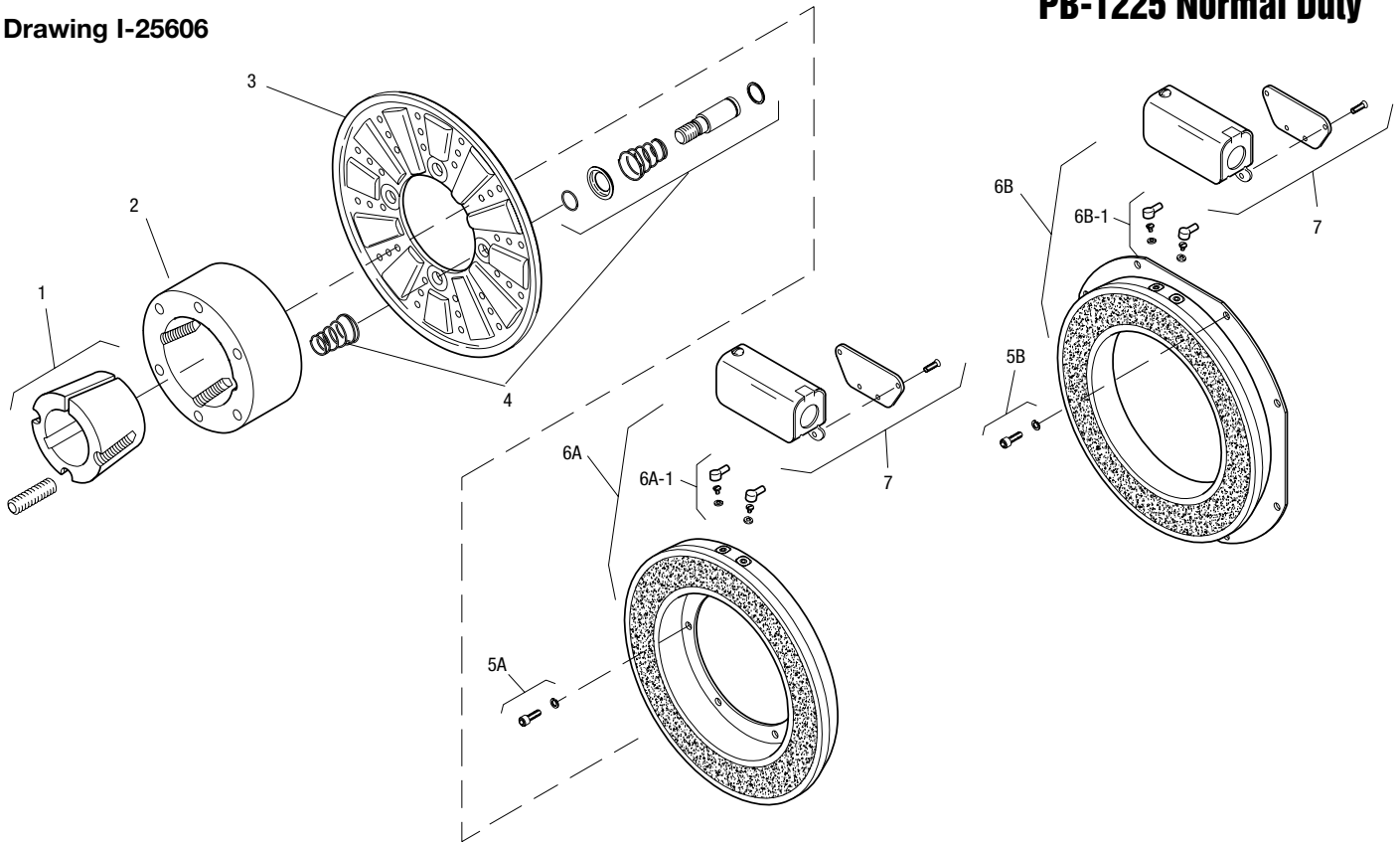

Item	Description	Part Number	Qty.
1	Bushing*		1
	15/16" to 3" Bore	180-0262 to 180-0295	
2	Armature Hub	540-0015	1
3	Armature	5303-111-009	1
4	Autogap Accessory	5201-101-008	4
5A	Mounting Accessory - I.M.	5321-101-001	1
5B	Mounting Accessory - O.M.	5321-101-002	2
6A	Magnet - Inside Mounted		1
	6 Volt	5313-631-005	
	24 Volt	5313-631-006	
	90 Volt	5313-631-007	
	†90 Volt	5313-631-001	
6A-1	Terminal Accessory	5311-101-001	1
6B	Magnet - Outside Mounted		1
	6 Volt	5313-631-010	
	24 Volt	5313-631-012	
	90 Volt	5313-631-011	
	†90 Volt	5313-631-002	

Item	Description	Part Number	Qty.
6B-1	Terminal Accessory	5311-101-001	1
7	Conduit Box	5200-101-011	1

How to Order:

1. Specify Bore Size for Item 1.
2. Specify Inside Mounted for Items 5A and 6A or Outside Mounted for Items 5B and 6B.
3. Specify Voltage for Item 6A or 6B.
4. See Controls Section.

Example:

PB-1225 Brake per I-25606 - 90 Volt, 1" Bore, Inside Mounted

These units, when used in conjunction with the correct Warner Electric conduit box, meet the standards of UL508 and are listed under guide card #NMTR, file #59164. These units are CSA certified under file #LR11543.

*See page 252 for specific part numbers.

Refer to Service Manual P-0208-WE

†Optional LK facing available. For more information, see page 232.

PB Series Brake

PB-1225 Heavy Duty

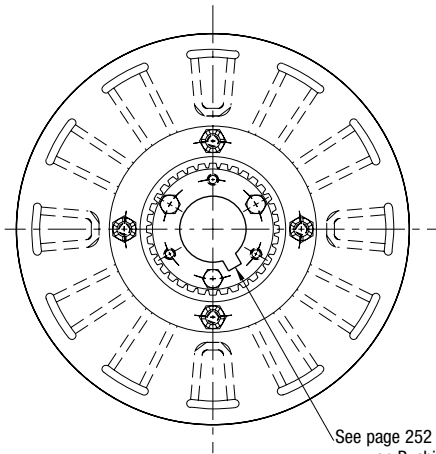

ARMATURE VIEW

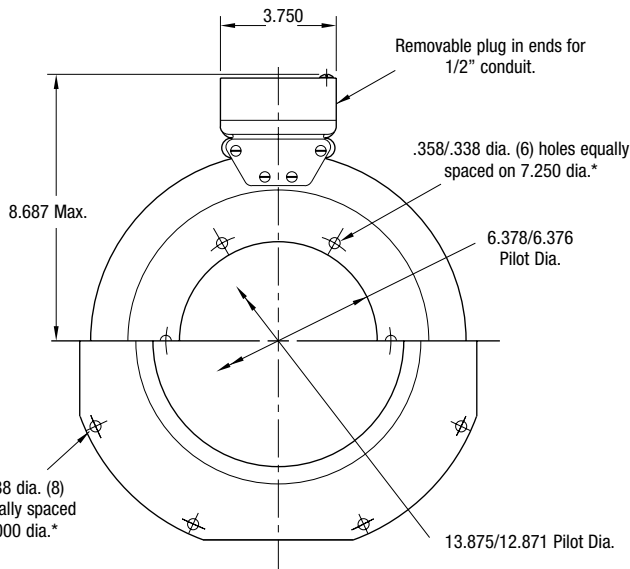
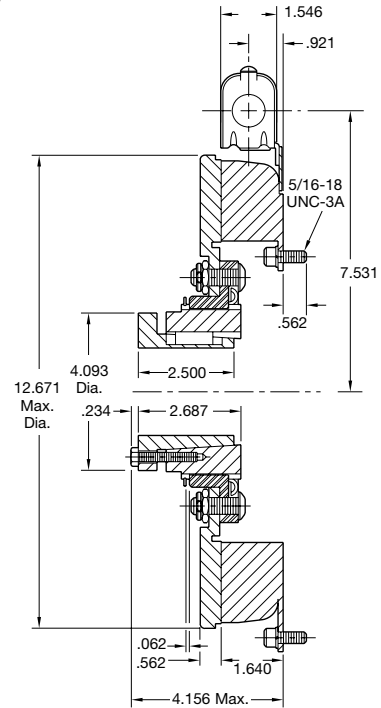

MAGNET VIEW

* Mounting holes are within .010 of true position relative to pilot diameter.

Customer Shall Maintain:

1. Squareness of magnet mounting face with armature shaft within .006 T.I.R.
2. Concentricity of magnet mounting pilot diameter with armature shaft within .010 T.I.R.



Shaft Size	.750 – 2.687
Static Torque	465 lb. ft.
Maximum Speed	3,000 rpm
Standard Voltage	D.C. 6, 24, 90

All dimensions are nominal unless otherwise noted.

Information on inertia and weights begins on page 239. Coil data is on pages 250 and 251.



PB-1225 Heavy Duty

Drawing I-25607

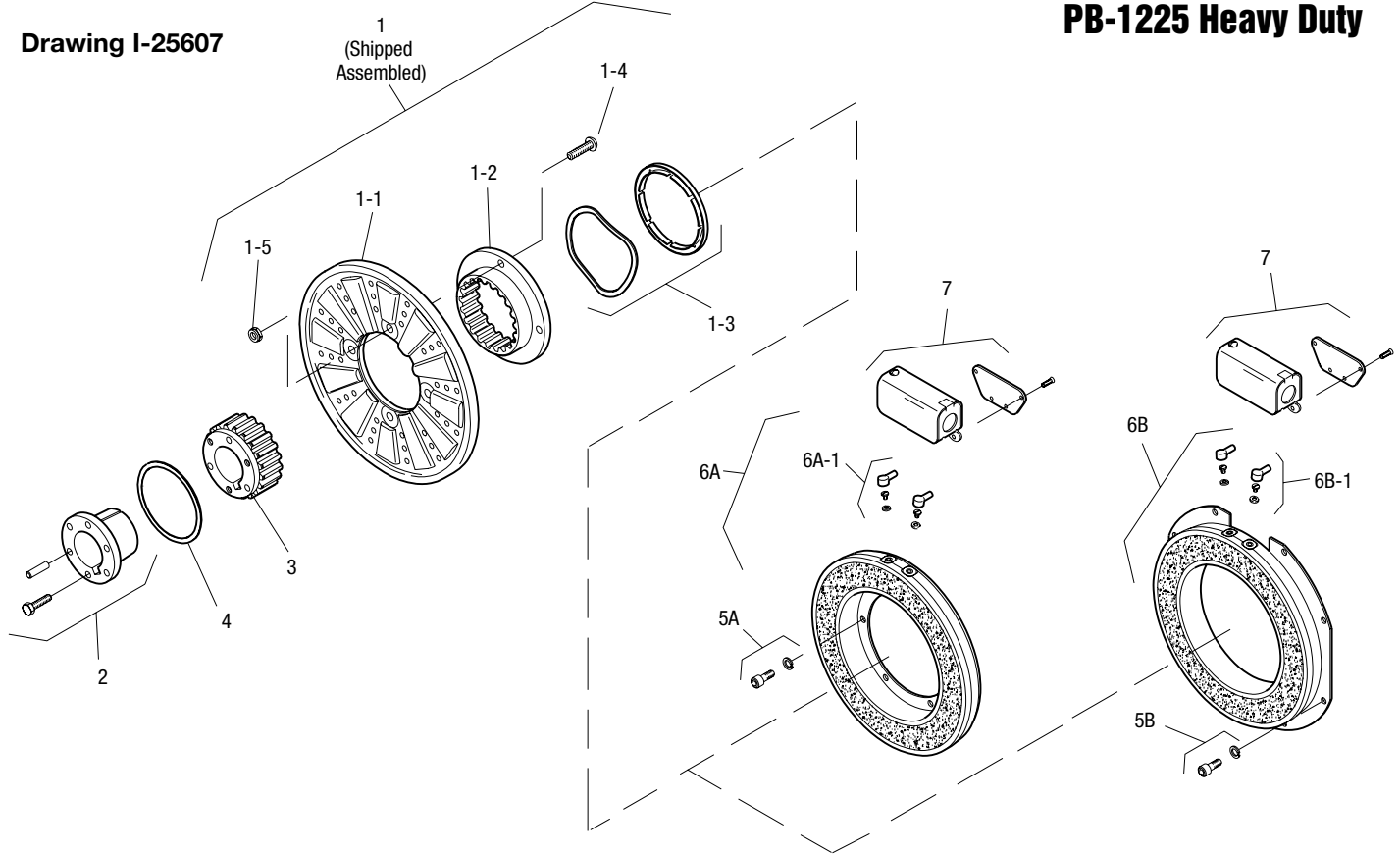

Item	Description	Part Number	Qty.
1	Armature & Splined Adapter	5323-111-001	1
1-1	Armature	5323-111-034	1
1-2	Splined Adapter	104-0010	1
1-3	Autogap Accessory	5323-101-002	1
1-4	Screw	797-0281	4
1-5	Locknut	661-0005	4
2	Bushing*		1
	3/4" to 2-11/16" Bore	180-0026 to 180-0057	
3	Splined Hub	540-0064	1
4	Retainer Ring	748-0005	1
5A	Mounting Accessory - I.M.	5321-101-001	1
5B	Mounting Accessory - O.M.	5321-101-002	2
6A	Magnet - Inside Mounted		1
	6 Volt	5313-631-005	
	24 Volt	5313-631-006	
	90 Volt	5313-631-007	
	†90 Volt	5313-631-001	
6A-1	Terminal Accessory	5311-101-001	1
6B	Magnet - Outside Mounted		1
	6 Volt	5313-631-010	
	24 Volt	5313-631-012	
	90 Volt	5313-631-011	
	†90 Volt	5313-631-002	

Item	Description	Part Number	Qty.
6B-1	Terminal Accessory	5311-101-001	1
7	Conduit Box	5200-101-011	1

How to Order:

1. Specify Bore Size for Item 2.
2. Specify Inside Mounted for Items 5A and 6A or Outside Mounted for Items 5B and 6B.
3. Specify Voltage for Item 6A or 6B.
4. See Controls Section.

Example:

PB-1225 Clutch per I-25607 - 90 Volt, 1-1/2" Bore, Inside Mounted

These units, when used in conjunction with the correct Warner Electric conduit box, meet the standards of UL508 and are listed under guide card #NMTR, file #59164. These units are CSA certified under file #LR11543.

*See page 252 for specific part numbers.

Refer to Service Manual P-0209-WE

†Optional LK facing available. For more information, see page 232.

PB Series Brake

PB-1525 Normal Duty



See page 252 for details on Bushings.

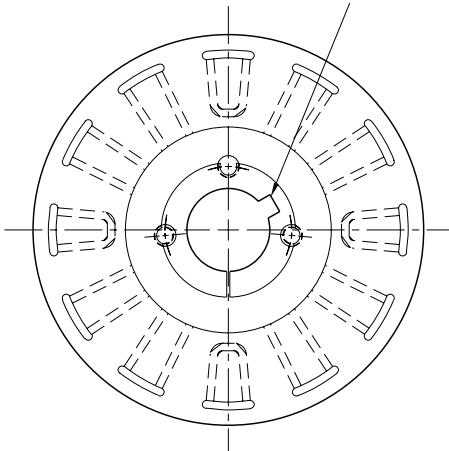

ARMATURE VIEW

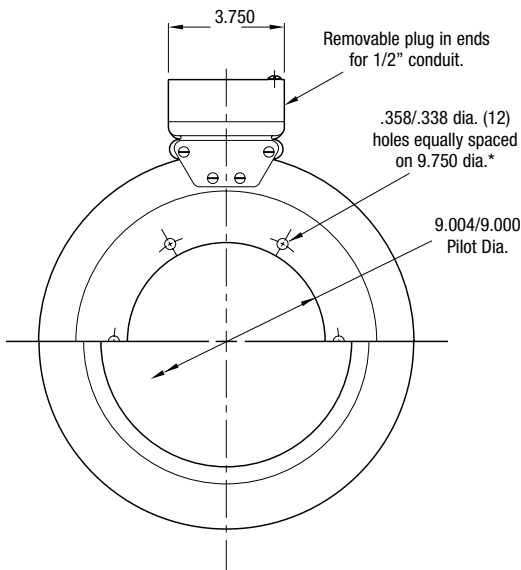

**MAGNET VIEW
(Inside Mounted)**

* Mounting holes are within .010 of true position relative to pilot diameter.

Customer Shall Maintain:

1. Squareness of magnet mounting face with armature shaft within .006 T.I.R.
2. Concentricity of magnet mounting pilot diameter with armature shaft within .010 T.I.R.

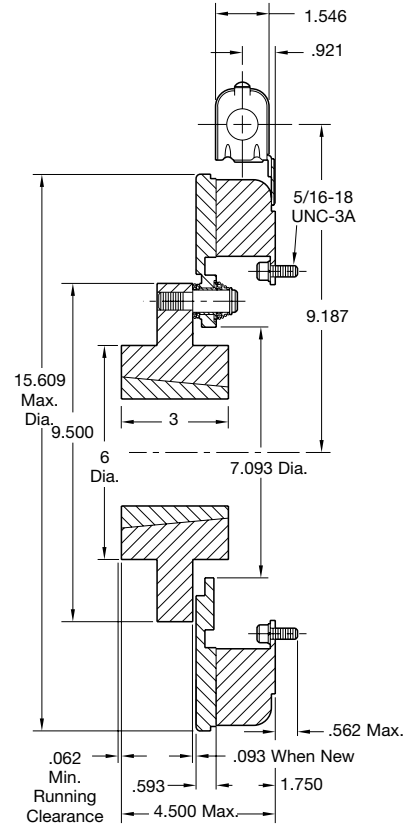

Shaft Size	.937 – 3.000
Static Torque	700 lb. ft.
Maximum Speed	2,000 rpm
Standard Voltage	D.C. 6, 24, 90

All dimensions are nominal unless otherwise noted.

Information on inertia and weights begins on page 239. Coil data is on pages 250 and 251.



Drawing I-25633

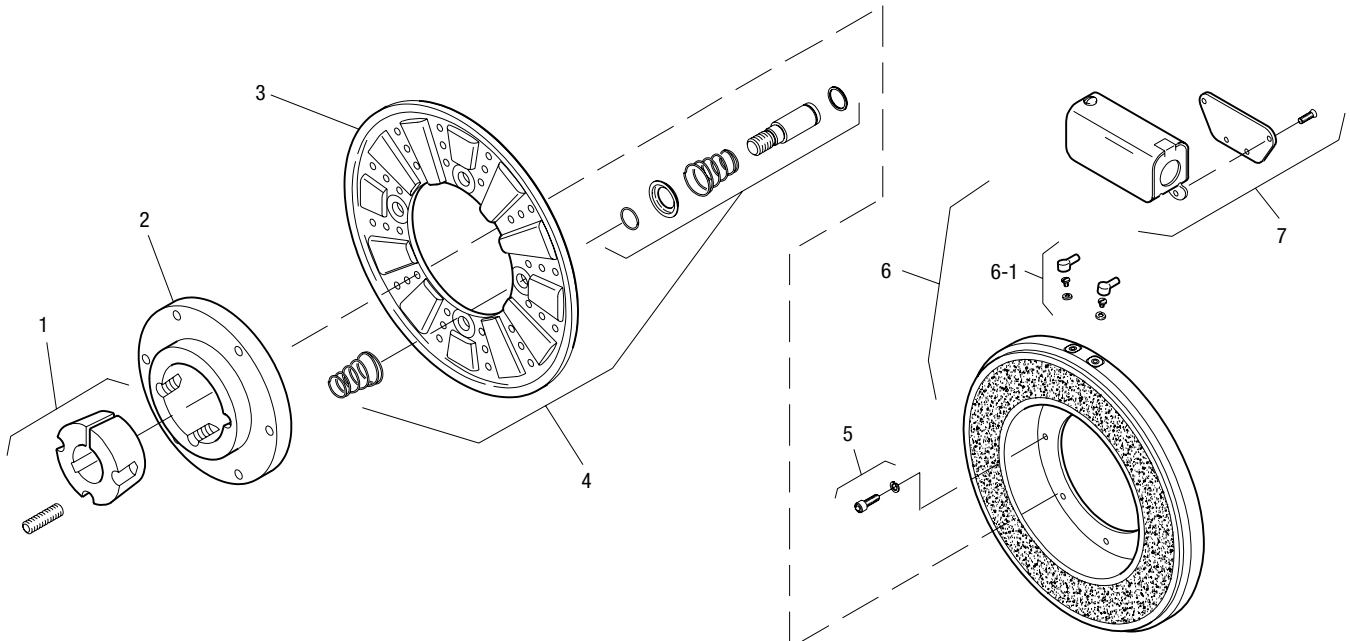

Item	Description	Part Number	Qty.
1	Bushing*		1
	15/16" to 3" Bore	180-0262 to 180-0295	
2	Armature Hub	540-0314	1
3	Armature	5304-111-004	1
4	Autogap Accessory	5201-101-008	4
5	Mounting Accessory - I.M.	5321-101-001	2
6	Magnet - Inside Mounted		1
	6 Volt	5314-631-004	
	24 Volt	5314-631-006	
	90 Volt	5314-631-005	
	†90 Volt LK Facing	5314-631-001	
6-1	Terminal Accessory	5311-101-001	1
7	Conduit Box	5200-101-011	1

How to Order:

1. Specify Bore Size for Item 1.
2. Specify Inside Mounted for Items 5 and 6.
3. Specify Voltage for Item 6.
4. See Controls Section.

Example:

PB-1525 Brake per I-25633 - 90 Volt, 1-1/2" Bore, Inside Mounted

These units, when used in conjunction with the correct Warner Electric conduit box, meet the standards of UL508 and are listed under guide card #NMTR, file #59164. These units are CSA certified under file #LR11543.

*See page 252 for specific part numbers.

Refer to Service Manual P-0208-WE

†Optional LK facing available. For more information, see page 232.

PB Series Brake

PB-1525 Heavy Duty

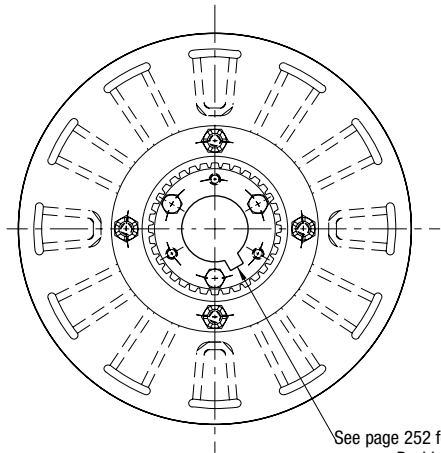

See page 252 for details on Bushings.

ARMATURE VIEW

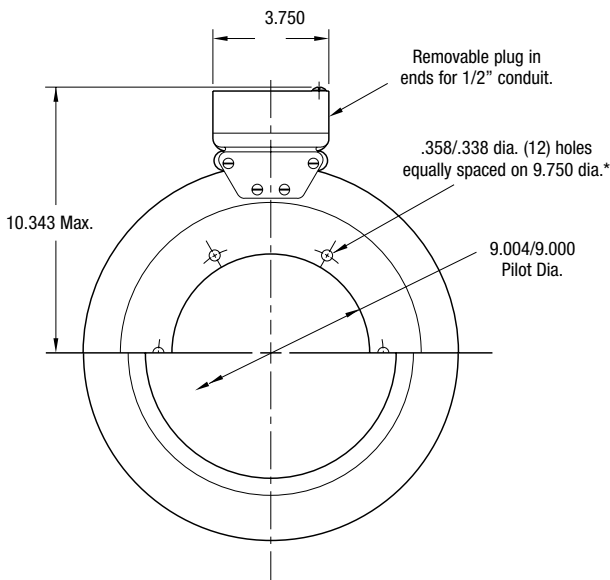

MAGNET VIEW

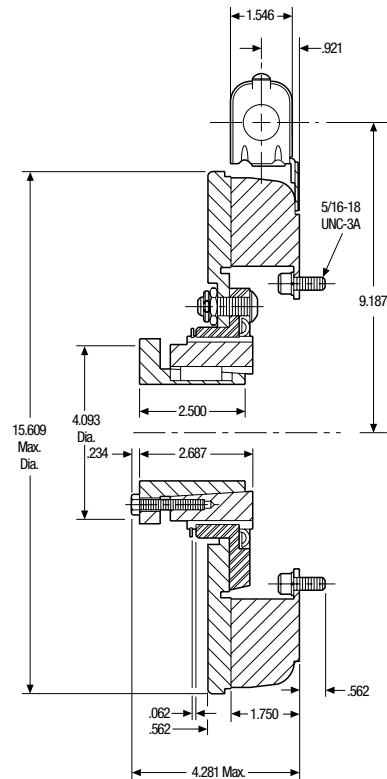

Shaft Size	.750 – 2.687
Static Torque	700 lb. ft.
Maximum Speed	2,000 rpm
Standard Voltage	D.C. 6, 24, 90

* Mounting holes are within .010 of true position relative to pilot diameter.

Customer Shall Maintain:

1. Squareness of magnet mounting face with armature shaft within .006 T.I.R.
2. Concentricity of magnet mounting pilot diameter with armature shaft within .010 T.I.R.

All dimensions are nominal unless otherwise noted.

Information on inertia and weights begins on page 239. Coil data is on pages 250 and 251.



PB-1525 Heavy Duty

Drawing I-25634

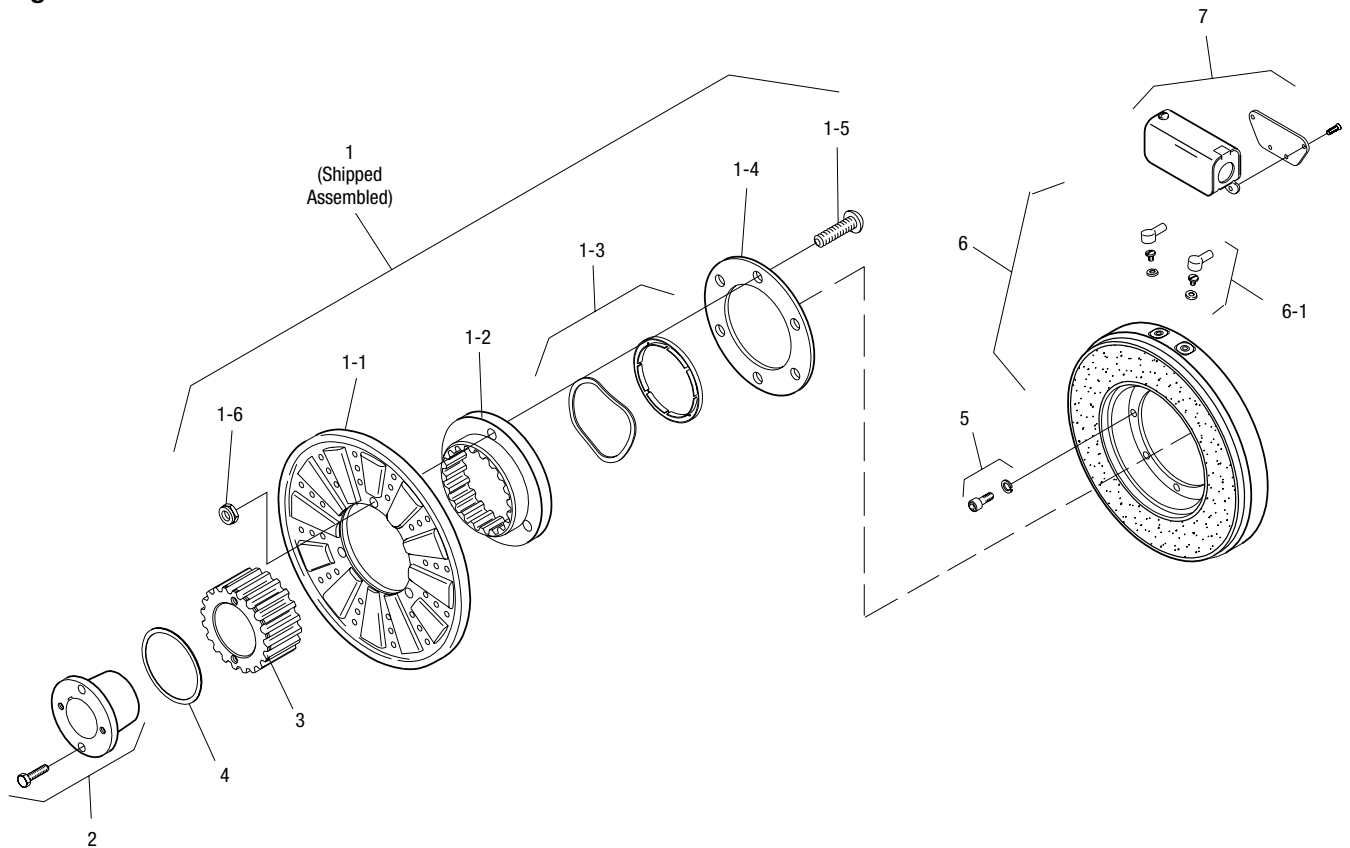

Item	Description	Part Number	Qty.
1	Armature & Splined Adapter	5324-111-001	1
1-1	Armature	5324-111-034	1
1-2	Splined Adapter	104-0011	1
1-3	Autogap Accessory	5323-101-002	1
1-4	Retainer Plate	686-0003	1
1-5	Screw	797-0272	8
1-6	Locknut	661-0004	8
2	Bushing*		1
	3/4" to 2-11/16" Bore	180-0026 to 180-0057	
3	Splined Hub	540-0064	1
4	Retainer Ring	748-0005	1
5	Mounting Accessory - I.M.	5321-101-001	2
6	Magnet - Inside Mounted		1
	6 Volt	5314-631-004	
	24 Volt	5314-631-006	
	90 Volt	5314-631-005	
	†90 Volt LK Facing	5314-631-001	
6-1	Terminal Accessory	5311-101-001	1
7	Conduit Box	5200-101-011	1

How to Order:

1. Specify Bore Size for Item 2.
2. Specify Inside Mounted for Items 5 and 6.
3. Specify Voltage for Item 6.
4. See Controls Section.

Example:

PB-1525 Clutch per I-25634 - 90 Volt, 1-3/4" Bore

These units, when used in conjunction with the correct Warner Electric conduit box, meet the standards of UL508 and are listed under guide card #NMTR, file #59164. These units are CSA certified under file #LR11543.

*See page 252 for specific part numbers.

Refer to Service Manual P-0209-WE

†Optional LK facing available. For more information, see page 232.